

Boost Converter Efficiency Through Accurate Calculations

By **Travis Eichhorn**, Senior Applications Engineer, National Semiconductor, Grass Valley, Calif.

Identifying all of the individual loss contributors enables the development of higher-order models for designing efficient boost-converter circuits.

Portable battery-operated electronic equipment is becoming packed with more features requiring larger amounts of power, leading to decreased operating times between battery charges.

Innovations such as dynamic backlight control, where the liquid crystal display's (LCD) backlight power is reduced based on screen content, and automatic voltage scaling, where a microprocessor's frequency and supply voltage are reduced based on computing time requirements, help to gain back those lost milliwatts. This milliwatt level of lost power is important considering the relatively low amounts of power consumed by a typical electronic device, and the small battery capacities that can often be rated at 1000 mAh or less. Essentially, everywhere that power loss can be accounted for helps in optimizing the design and aids in extending battery life.

One contributor to power loss in portable electronic devices is the inductive boost-switching regulator. These types of converters are typically used to power white light-emitting diodes (LEDs) in back-lit LCDs, organic LED panels, high-current flash LEDs, or even audio amplifiers.

Although inductive boost converters can be highly efficient, improper selection of a converter type, operating frequency and/or external components can lead to an inefficient design. Therefore, making accurate efficiency calculations helps to identify the individual loss contributors and provides the insight necessary in designing an efficient boost converter.

To begin with, take a standard asynchronous boost converter. The simple approximation to efficiency can be made using a first-order model where the ideal duty cycle (D) = $(V_{OUT} - V_{IN})/V_{OUT}$ and the average inductor current, or input current (I_{IN}), $I_{IN} = (I_{OUT}/1 - D)$ is used to estimate the dc losses in the NMOS switch, the Schottky diode and the inductor.

Efficiency then becomes:

$$\text{eff} = \frac{P_{IN} - (P_{SWITCH} + P_{INDUCTOR} + P_{DIODE})}{P_{IN}}$$

where $P_{SWITCH} = R_{NMOS} \times D \times (I_{OUT}/1 - D)^2$, $P_{INDUCTOR} = R_L \times (I_{OUT}/1 - D)^2$ and $P_{DIODE} = R_D \times I_{OUT}^2 + V_F \times I_{OUT}$.

This model makes for a rough estimate; however, the initial approximation for duty cycle ignores the circuit's internal losses and ends up underestimating the duty cycle as well as the input current. Essentially, the duty cycle must increase to overcome the circuit's internal losses. Consequently, the initial calculation for the duty cycle should have involved the component of efficiency or, more specifically:

$$D = \frac{V_{OUT} - V_{IN} \times \text{eff}}{V_{OUT}}$$

This can be found by using the equation $V_{IN} \times I_{IN} \times \text{eff} = V_{OUT} \times I_{OUT}$, substituting $I_{IN} = (I_{OUT}/1 - D)$ and solving for D . Because of this, the first-order model's efficiency estimate will increasingly deviate from the actual efficiency as the power loss between the input and the output increases.

Accounting for this requires a model that computes the duty cycle based on the power-loss components and then uses this value to calculate the circuit's input current, again via the ratio $I_{IN} = (I_{OUT}/1 - D)$.

In developing this model, consider the power balance in the boost regulator $P_{IN} = P_{LOSS} + P_{OUT}$. This states that the total input power is equal to the output power plus the power lost in each of the circuit's components. Again, using a typical asynchronous boost converter, the dc losses in the NFET switch, the diode and the inductor are used to generate a power-balance equation given by $P_{IN} = P_{SWITCH} + P_{DIODE} + P_{INDUCTOR} + P_{OUT}$.

Substituting $I_{IN} = (I_{OUT}/1 - D)$, as was done before in the first-order model, leads to the modified power-balance equation:

$$\frac{V_{IN} \times I_{OUT}}{1-D} = V_F \times I_{OUT} + R_D \times I_{OUT}^2 + R_N \times \left(\frac{I_{OUT}}{1-D}\right)^2 D + R_L \times \left(\frac{I_{OUT}}{1-D}\right)^2 + V_{OUT} \times I_{OUT}$$

Instead of using the ideal duty-cycle ratio $D = (V_{OUT} - V_{IN})/V_{OUT}$, the power-balance equation is now used to solve directly for D . Multiplying by $(1 - D)^2$ and collecting the terms on one side gives a second-order polynomial for the duty cycle:

$$D^2 \times (V_F \times I_{OUT} + V_{OUT} \times I_{OUT} + R_D \times I_{OUT}^2) + D \times (R_N \times I_{OUT}^2 + V_{IN} \times I_{OUT} - 2 \times V_F \times I_{OUT} - 2 \times V_{OUT} \times I_{OUT}) + (R_L \times I_{OUT}^2 + V_F \times I_{OUT} + V_{OUT} \times I_{OUT} - V_{IN} \times I_{OUT}) = F(D)^2$$

This becomes the second-order model that generates two solutions for D , one of which is correct (the first zero crossing of $F(D)$ versus increasing D) and the other (the second crossing) is not. This can be solved using the quadratic formula.

Since only the dc losses are accounted for in this model, the efficiency estimate is only accurate when the converter operates in the continuous-conduction mode (CCM) with relatively small inductor current ripple and when the dc losses are much bigger than the switching losses. However, when this is not the case and the peak-peak inductor current ripple approaches $(2 \times I_{OUT})/1 - D$ and/or switching losses begin to approach or surpass the dc conduction losses,

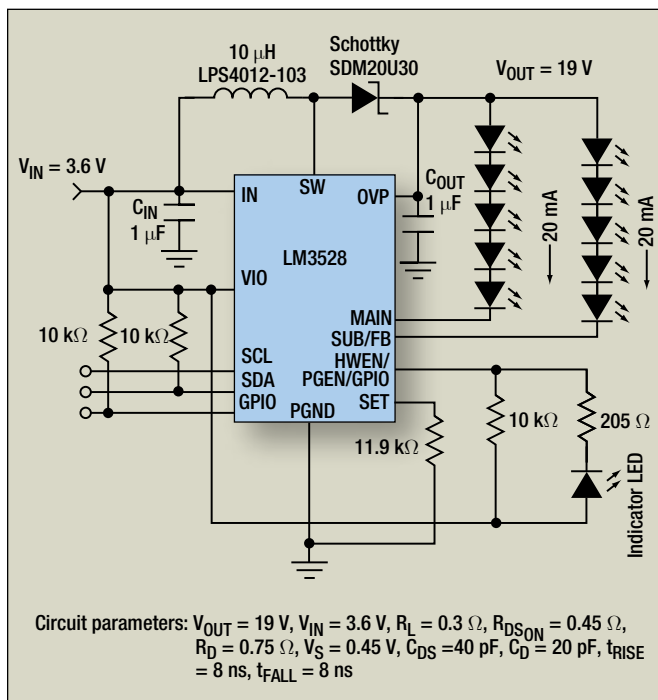
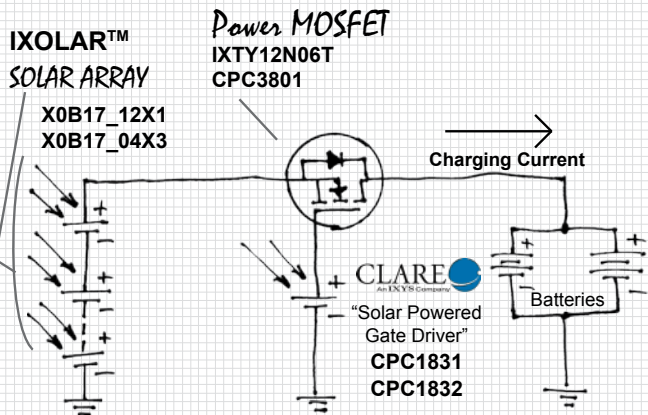

Fig. 1. Calculating boost-converter efficiency using conventional first- and second-order models can be inaccurate, as is the case for this LM3528 white LED driver circuit. Higher-order modeling yields more accurate results.

High Efficiency Solar Charging ...

IXYS SOLAR POWER!



GREAT FOR CHARGING BATTERIES

With our solar components, designing a high-efficiency solar power solution is now simpler than ever!

Applications

- NiMH, NiCad, Alkaline, etc.
- Laptops, Cell phones, MP3 players
- GPS, Portable test equipment, Flashlights
- Security cameras
- Remote sensors
- Electric fences
- RV & automotive
- UPS



For more information, visit
www.ixyscolorado.com
and www.clare.com

For technical information,
call Gib Bates at
(970) 493-1902 ext. 22

this model begins to deviate from the actual efficiency, much the same way as the first-order model did.

To show the error in the first- and

second-order models, consider an asynchronous boost converter such as National Semi's LM3528, which is designed to power two strings of white

LEDs in an LCD backlight (Fig. 1). With the given circuit parameters, the measured efficiency is 83%.

Using the first-order model, the estimated duty cycle is:

$$D = \frac{V_{OUT} - V_{IN}}{V_{OUT}} = \frac{19 - 3.6}{19} = 0.81.$$

The input current is calculated as:

$$I_{IN} = \frac{I_{OUT}}{1 - D} = 211 \text{ mA}.$$

The dc conduction losses in the NFET become:

$$D \times I_{IN}^2 \times R_N = 18 \text{ mW}.$$

The diode losses become:

$$V_F \times I_{OUT} + I_{OUT}^2 \times R_D = 19.2 \text{ mW}.$$

And the inductor loss becomes:

$$I_{IN}^2 \times R_L = 15.6 \text{ mW}.$$

This gives an approximated efficiency of:

$$\frac{P_{IN} - P_{LOSS}}{P_{IN}} = \frac{V_{IN} \times I_{IN} - P_L - P_N - P_D}{V_{IN} \times I_{IN}} = 93\%.$$

The second-order estimate should yield a closer approximation to the actual efficiency since the circuit's internal losses are included in calculating the duty cycle. Taking the converter's parameters and using the quadratic formula to solve for D in the equation $F(D^2)$ gives a duty cycle of 0.825. This results in a slightly lower efficiency:

$$\frac{V_{OUT} - D \times V_{OUT}}{V_{IN}} = 92.4\%.$$

However, this efficiency is still quite a ways off from the actual value.

Switching Losses

Where does the problem lie? For boost converters such as white LED drivers that operate with such low output currents and high duty cycles, the switching losses are no longer trivial compared to the circuit's conduction losses. The switching-loss components must be included in the second-order power-balance equation to give a more accurate estimate of the duty cycle and a closer calculation of circuit efficiency.

To start with, the primary switching-power loss components in an

	Continuous conduction normalized to I_{OUT}^2	Discontinuous conduction
NFET dc power	$P_{NDC} = R_{NFET} \times I_{OUT}^2 \times D$	$P_{NDC} = 0$
NFET power loss due to ripple current	$P_{NAC} = \frac{R_{NFET} \times I_{AC}^2}{12} \times D^3 \times (1-D)^2$	$P_{NAC} = \frac{I_{AC}^2}{3} \times R_{NFET} \times D^3$
Inductor dc power loss	$P_{LDC} = R_L \times I_{OUT}^2$	$P_{LDC} = 0$
Inductor power loss due to ripple current	$P_{LAC} = \frac{R_L \times I_{AC}^2}{12} \times D^2 \times (1-D)^2$	$P_{NAC} = \frac{I_{AC}^2}{3} \times R_L \times \left(D^3 + \frac{I_{OUT} \times 2 \times f_{SW} \times L}{V_{IN}} \times D \right)$
Diode resistance dc power loss	$P_{RDc} = R_D \times I_{OUT}^2 \times (1-D)$	$P_{RDc} = 0$
Diode resistance power loss due to ripple current	$P_{RDAC} = \frac{R_D \times I_{AC}^2}{12} \times D^2 \times (1-D)^3$	$P_{RDAC} = \frac{I_{AC}^2}{3} \times R_D \times \frac{I_{OUT} \times 2 \times f_{SW} \times L}{V_{IN}} \times D$
Power required for C_{DS} capacitor	$P_{CDS} = \frac{V_{OUT}^2 \times C_{DS} \times f_{SW}}{2} \times (1-D)^2$	$P_{CDS} = \frac{V_{OUT}^2 \times C_{DS} \times f_{SW}}{2}$
Power required for C_D capacitor	$P_{CD} = \frac{V_{OUT}^2 \times C_D \times f_{SW}}{2} \times (1-D)^2$	$P_{CD} = \frac{V_{OUT}^2 \times C_D \times f_{SW}}{2}$
I_{DS} and V_{DS} overlap losses due to inductor dc current	$P_{CCDC} = \frac{V_{OUT} \times I_{OUT}}{2} \times (t_{RISE} + t_{FALL}) \times f_{SW}$	$P_{CCDC} = 0$
I_{DS} and V_{DS} overlap losses due to inductor ripple current	$P_{CCAC} = \frac{V_{OUT} \times I_{OUT}}{4} \times (t_{RISE} - t_{FALL}) \times f_{SW} \times D \times (1-D)^2$	$P_{CCAC} = \frac{V_{OUT} \times I_{AC}}{2} \times (t_{FALL}) \times f_{SW} \times D$
Diode reverse recovery charge loss	$P_{QRR} = V_{OUT} \times Q_{RR} \times f_{SW} \times (1-D)^2$	$P_{QRR} = V_{OUT} + Q_{RR} \times f_{SW}$
Output power	$P_{OUT} = I_{OUT} \times V_{OUT} \times (1-D)^2$	$P_{OUT} = I_{OUT} \times V_{OUT}$
Input power	$P_{IN} = I_{OUT} \times V_{IN}$	$P_{IN} = \frac{I_{AC} \times V_{IN}}{2} \times \left(\frac{I_{OUT} \times f_{SW} \times L \times 2}{V_{IN}} + D^2 \right)$
Input current	$I_{IN} = \frac{I_{OUT}}{1-D}$	$I_{IN} = \frac{V_{IN}}{L \times f_{SW} \times 2} \times D^2 + I_{OUT}$

Table. Power-loss components for continuous and discontinuous conduction (asynchronous boost converter).

asynchronous boost converter include the power due to the MOSFET cross conduction (P_{CC}), which is the overlap between the current and voltage during the switch turn-on and turn-off, the charging of the Schottky diode's capacitance with each switching cycle (P_{CD}), and the charging of the NFET switch's drain-to-source capacitance each switching cycle (P_{CDS}).

Adding these to the power-balance equation gives a more complicated (but accurate) equation of the duty cycle. The new second-order power-balance equation becomes:

$$\frac{V_{IN} \times I_{OUT}}{1-D} = \left(V_F \times I_{OUT} + R_D \times I_{OUT}^2 + R_N \times \left(\frac{I_{OUT}}{1-D} \right)^2 + R_L \times \left(\frac{I_{OUT}}{1-D} \right)^2 \right) + \left(\frac{1}{2} \times C_{DS} \times V_{OUT}^2 \times f_{SW} + \frac{V_{OUT}}{2} \times \frac{I_{OUT}}{1-D} \times (t_{RISE} + t_{FALL}) \times \left(f_{SW} + \frac{1}{2} \times V_{OUT}^2 \times C_D \times f_{SW} \right) \right) + V_{OUT} \times I_{OUT}$$

This results in a modified second-order equation for a duty cycle of:

$$D^2 \times \left(V_F \times I_{OUT} + V_{OUT} \times I_{OUT} + R_D \times I_{OUT}^2 + \frac{(C_{DS} + C_D) \times V_{OUT}^2}{2} \times f_{SW} \right) + D \times \left(R_N \times I_{OUT}^2 + V_{IN} \times I_{OUT} - 2 \times V_F \times I_{OUT} - 2 \times V_{OUT} \times I_{OUT} - (C_{DS} + C_D) \times V_{OUT}^2 \times f_{SW} - \frac{V_{OUT} \times I_{OUT}}{2} \times (t_{RISE} + t_{FALL}) \times f_{SW} \right) = F(D^2)$$

Using C_{DS} equals 40 pF, C_D equals 20 pF and t_{RISE} equals t_{FALL} equals 8 ns results in an estimated duty cycle of 83.8% for the LM3528. This results in a calculated efficiency of 85.5%, which is much closer to the measured value.

Higher-Order Model

Until now, the duty-cycle calculations assumed no ripple current, which isn't a problem because an average inductor current is used instead of root-mean-square (rms) inductor current. And assuming the converter operates in the CCM only changes the previous answer a slight amount. However, with boost circuits operating at such low-output power levels, it is likely that a large portion of the load current will cause the converter to operate in a discontinuous conduction mode (DCM).

Unfortunately, the previous calculations only applied to the CCM. If the designer wants to model the DCM efficiency, then the ripple current is no longer trivial. Furthermore, to calculate efficiency over the entire load-current range, ignoring the ripple current in the CCM and then including it in the DCM would lead to a discontinuity in efficiency as the load current transitions through the modes.

The solution is to include the ripple current in the CCM duty-cycle equation and also solve for the duty cycle using a separate equation for the DCM. The DCM equation is developed using a power-balance equation in much the same way as for the CCM case.

As a starting point, the rms value of a triangle waveform, which is the true inductor current, is given by:

$$I_{RMS} = \sqrt{d} \times \sqrt{I_{LDC}^2 + I_{LDC} \times \frac{\Delta I_L^2}{3}}$$

I_{LDC} is the dc or average value of the inductor current, which is $I_{OUT}/1-D$ for the CCM and zero for the DCM. ΔI_L is the peak-to-peak inductor current ripple and is given by $(\Delta I_L = V_{IN} \times D / (f_{SW} \times L))$ for both the CCM and the DCM. Finally, d is the portion of

Standard and Custom Power Transformer Solutions

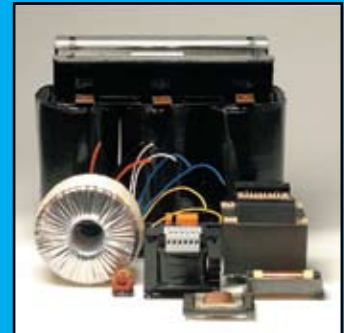

- ▶ Laminated and Toroidal Power Transformers, Inductors, and Custom High Frequency Magnetics
- ▶ Capabilities from 0.1 VA to 45 KVA
- ▶ PC and Chassis Mount
- ▶ RoHS-Compliant Products
- ▶ UL, CSA, VDE, IEC, and EN Certified
- ▶ In-House Agency Certification Program
- ▶ Large, Finished Goods Inventory

Custom Designs Welcome!

PRONTO®
 24 HOUR SHIPPING!
 Phone: 866/239-5777
 Fax: 516/239-7208

Signal Transformer

www.signaltransformer.com
sales@signaltransformer.com

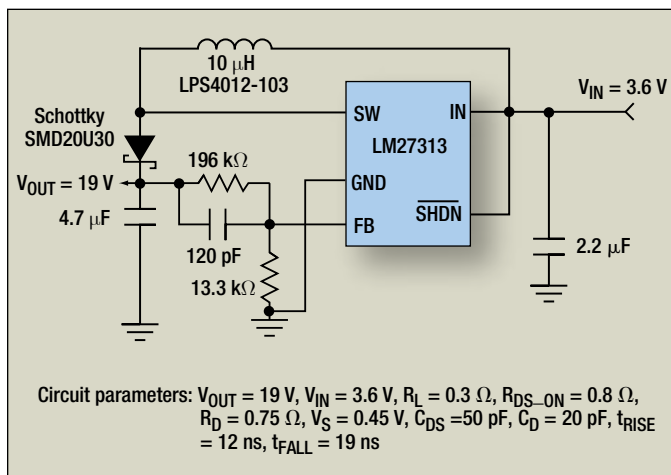

Fig. 2. This LM27313 boost converter operates in either the CCM or DCM mode over the entire load current range. It provides a more direct comparison with the developed higher-order model used in the measured versus calculated efficiency plots of Figs. 3 and 4.

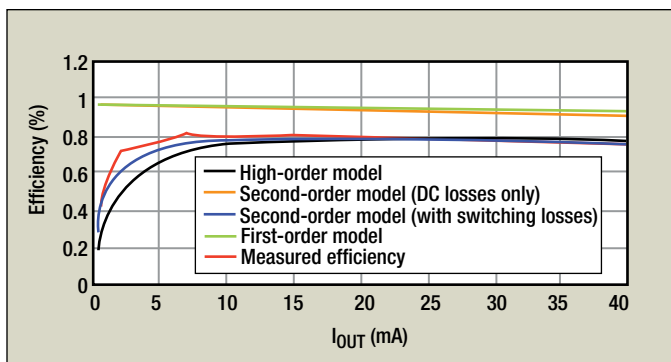

Fig. 3. Calculated versus measured efficiency levels (for the circuit in Fig. 2) using the higher-order model and a modified higher-order model to account for C_D and C_{DS} at light currents.

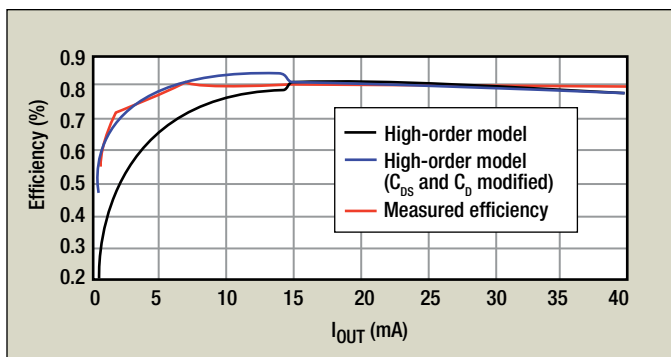

Fig. 4. Calculated versus measured efficiency levels (for the circuit in Fig. 2) using second-order and higher-order models.

the switching period that the rms current is conducting.

For example, $d = D$ for the components conducting during the switch-on time in both the CCM and the DCM; $d = (1 - D)$ for the components conducting during the off time in the CCM and $d = (2 \times I_{OUT}) / \Delta I_L$ for the components conducting during the off time in the DCM; and lastly, $d = 1$ for the components conducting during both portions

of the period in the CCM and $d = D + (2 \times I_{OUT}) / \Delta I_L$ for the components conducting during the first two portions of the period in the DCM.

Adding the ripple component to the $F(D^2)$ equation adds a third-, fourth- and fifth-order term for the resistive power-loss components. On the other hand, the DCM equation becomes a third-order polynomial. To avoid the complexity of drawing out these equations, the table categorizes the power-loss components in the asynchronous boost converter with the factored D terms to the right. In the table, the first column lists the CCM components and the second column lists the DCM components.

Each term in the CCM column is normalized to I_{OUT} (i.e., it is divided by $(1 - D)^2$ to eliminate the $(1 - D)^2$ term in the denominator). The I_{AC} term is the inductor current slope over the entire switching period (or the inductor current ripple divided by D). Collecting the terms of the power-loss components in the CCM column results in the fifth-order polynomial, $F_{CCM}(D^5) = a \times D^5 + b \times D^4 + c \times D^3 + d \times D^2 + e \times D^1 + f \times D^0$, and collecting the terms of the power-loss components in the DCM column gives a third-order polynomial, $F_{DCM}(D^3) = g \times D^3 + h \times D^2 + j \times D^1 + k \times D^0$, where the a through k coefficients are functions of the circuit parameters V_{IN} , V_{OUT} , I_{OUT} , R_N , R_L , etc.

This higher-order model using both the $F_{CCM}(D^5)$ and $F_{DCM}(D^3)$ equations has no simple solution like the $F(D^2)$ equation. Fortunately, as with $F(D^2)$, the useful solutions to the fifth- and third-order polynomials are those occurring at the first crossing of zero with increasing D .

Finding this solution is possible, using a spreadsheet like Excel, by setting $F(D^5)$ and $F(D^3)$ to zero and plotting $F(D)$ versus D and varying D from zero to one. Alternatively, implementing the functions $F_{CCM}(D^5)$ and $F_{DCM}(D^3)$ in C and using a “while” loop to test for the first $F(D) = 0$ crossing versus increasing D works, also.

Comparing the calculated values with measured values using the higher-order model requires that a converter be used that operates in either the CCM or the DCM. Unfortunately, the LM3528 operates in a pulse-skip mode to improve efficiency at light loads. This would require a third equation to model the converter in this mode. Additionally, using a white LED driver adds an extra layer of complexity in the calculations since the LED voltage changes with I_{OUT} .

To remedy this, the LM27313 standard asynchronous boost converter will be used to compare the calculated versus measured results of the efficiency estimations (Fig. 2). This converter operates in either the CCM or the DCM over the entire load current range, thus providing a more direct comparison with the developed higher-order model.

Figs. 3 and 4 use the equations developed so far for the first-, second- and higher-order models to calculate D and solve for efficiency versus output current. The LM27313’s output voltage is held at 19 V over the entire load current range of 0 mA to 40 mA (Fig. 2).

Fig. 3 compares the first-order model, the second-order model, both with and without switching losses, the higher-

order model and the measured efficiency. Fig. 4 also compares the measured efficiency with the calculated efficiency using the higher-order model as previously described, and the higher-order model that is slightly modified to account for changes in C_D and C_{DS} capacitive energy losses at very light loads.

The first-order model again uses the ideal duty-cycle ratio and calculates efficiency at each I_{OUT} . Both second-order models (for dc losses only) and second-order switching losses use the $F(D^2)$ equation and solve for D at each I_{OUT} using the quadratic formula. The higher-order model uses C code and iterates through the $F_{CCM}(D^5)$ equation by varying D between 0 and 1 while testing for the first zero crossing. At the end of each $F_{CCM}(D^5)$ iteration, a comparison is done between the calculated inductor current ripple and the average inductor current to determine when:

$$\left(\frac{1}{2} \times \Delta I_L\right) > \frac{I_{OUT}}{1-D}$$

When this happens, the converter is assumed to be in the DCM, and the $F_{DCM}(D^3)$ equation is then iterated to calculate D . This is done at each I_{OUT} to generate the efficiency graph.

As would be expected, the first- and second-order (dc only) models show a lot of variation between the calculated and actual efficiency. The second-order model, which includes switching losses, is the closest at low currents while the higher-order model is closer at high currents, but tends to deviate at low currents when the device operates further into the DCM.

This can be explained by understanding how the boost-circuit capacitances charge and discharge each switching cycle as the boost converter transitions from the CCM to the DCM. When the converter is operating fully in the CCM, the drain-to-source and diode capacitances charge and discharge from zero to V_{OUT} , each cycle causing a power loss of:

$$P_C = \frac{V_{OUT}^2 \times (C_{DS} + C_D) \times f_{SW}}{2}$$

As the converter transitions from the CCM to the DCM (i.e., the load current decreases), the inductor current slope will hit zero before the end of the switching period. If the inductor current hits zero well before the end of the switching period, the inductor current will begin to go negative, causing the energy in the switching node capacitances to return back to V_{IN} . As the load current is further reduced, the dead

time increases and a damped ringing develops between the switching node capacitances and the inductor. Eventually this voltage ringing will decay to V_{IN} .

The result is that as the converter transitions more and more into the DCM, the switching node capacitances will give a lot of their energy back to the input and essentially have to charge up to a smaller and smaller voltage. At the extreme minimum current, when the switching node has discharged down to V_{IN} before the start of a new switching period, the drain-to-source and diode capacitance power loss becomes closer to:

$$P_C = \frac{V_{IN}^2 \times (C_{DS} + C_D) \times f_{SW}}{2}$$

If the third-order DCM equation is made to reflect this, then the efficiency versus load current becomes closer to the actual efficiency at light currents (Fig. 4). The discontinuity in the modified higher-order plot occurs at the CCM/DCM boundary where the C_{DS} and C_D capacitance voltage begins shifting from V_{OUT} down to V_{IN} .

Another source of error that was left out of the duty-cycle calculations is that due to inductor switching losses (core loss and eddy currents). This would tend to decrease the efficiency even further when the converter operates in the DCM due to the large current ripple. Unfortunately, inductor ac switching-loss values are not commonly given, so they were not used in these examples.

PETech

Holy Stone
A POWERFUL PRESENCE
IN POWER APPLICATIONS

Holy Stone offers a variety of MLCCs specifically designed for power applications.

- ▶ High Capacitance X7R for DC/DC Input/Output Filtering
- ▶ High Voltage Capacitors for a variety of power apps
- ▶ High Capacitance MLCCs for DC/DC smoothing
- ▶ High Voltage and Safety Certified Disc Capacitors
- ▶ Stacked High C/V for Switch Mode Power Supplies

Holy Stone MLCCs are available with Arc Prevention Coating and SuperTerm™ a polymer layer that reduces the risk of internal cracks.

HolyStone International
 A subsidiary of Holy Stone Enterprise Co.

26395 Jefferson Ave., Suite H, Murrieta, CA 92562 Tel: 951-696-4300 Fax: 951-696-4301
 Email: info@holystonecaps.com Web: www.holystonecaps.com
 In Europe: www.holystoneeurope.com In Asia: www.holystone.com.tw