



# POWER MOTOR

An integrated motor drive power IC is space and power efficient with an architecture scalable to higher current levels. A fully protected dual high-side MOSFET power switch has an entire H-bridge control. With two additional low-side MOSFETs, it limits the inrush current to a dc motor, drives it in both directions, and offers a braking mode.

**M**otors play a key role in the increasing comfort and convenience in today's vehicles, providing functions from adjusting seats or headlamps to lifting windows and moving sunroof doors. However, making the motor easy to control, safe, and reliable in an automotive system in a cost-effective fashion isn't an easy task. Over half of the motors in today's vehicles (by function alone—many have multiple uses) conduct less than an average of 6A. Automotive applications for an H-bridge motor drive include any brush type dc motor, such as seat and windshield wiper motors, and many other body electronics applications.

A new power management IC, the IR3220, implements a cost-effective motor drive for automotive applications. It handles switching, reversing, and protection to save cost, cut motor drive space, and simplify electrical and thermal design. This power IC integrates the H-bridge control and

protection functions with two high-side (HS) MOSFETs. Completing the H-bridge are two low-side (LS) MOSFET switches in separate packages. The IC provides overcurrent protection against short circuits in the associated motor. It also includes overtemperature shutdown, in case the motor encounters problems. Also included is a soft-start (SS) circuit that limits inrush current and produces a smooth and stress-free ramp-up. Additional safety features include undervoltage lockout, overvoltage protection from integrated active clamping circuitry, non-braking mode, and diagnostic feedback.

HS switches are integrated in the controller to provide ease of drive, directional capability, and H-bridge protection. LS MOSFETs are separate to provide flexibility by offering the high-frequency switching ability for the SS function. Fig. 1, on page 18, shows the dc motor drive architecture. The control circuit and HS drivers are in a surface-mount SO20 package. Two LS MOSFETs are each in SO8

By Randy Frank, International Rectifier, El Segundo, Calif.; and Xavier de Frutos, International Rectifier, Aix En Provence, France

# IC PROTECTS DRIVES

packages. The combination provides forward, reverse, and braking for up to an 80W dc motor.

## Design Principles

Two of the four transistors produce the H-bridge output. One HS and the diagonally opposite LS conduct at one time, and then the other HS and LS switches conduct the next time. Only one set of output transistors or one leg should conduct current at a time. If both sets try to conduct at the same time, you get a shoot-through condition. If that occurs, the power IC can be destroyed. The IR3220 provides a novel and fail-safe approach to protection against shoot-through (Fig. 2, on page 18).

The IR3220 architecture relies on four basic principles:

- Each leg of the H-bridge is totally independent of the other leg.
- Each leg contains separate current protection and a shoot-through prevention circuit that eliminates

diagonal commands among the four MOSFETs.

- The normal quiescent state of the two LS MOSFETs is ON. To avoid conflicts, the shoot-through prevention circuit generates the proper LS command.
- An internal SS circuit sends a PWM signal to both LS MOSFETs without considering the H-bridge direction. Therefore, the PWM circuit is almost independent and offers flexibility for extended operations (controlling the speed or the torque.)

Each principle provides inherent safety for the H-bridge topology. Control functions such as undervoltage lockout, non-braking mode, temperature protection, and the diagnostic feedback are contained in the “IC logic control” functional block in Fig. 3, on page 18.

The two HS switches have an  $R_{DS(on)} = 12 \text{ m}\Omega$  (typical) and can handle  $I_{DC} = 6\text{A}$  at  $85^\circ\text{C}$ . The control circuit can operate with  $V_{CC} = 5.5\text{V}$  to  $35\text{V}$  and provide  $I_{shutdown} = 30\text{A}$  and  $T_{shutdown} = 165^\circ\text{C}$ .

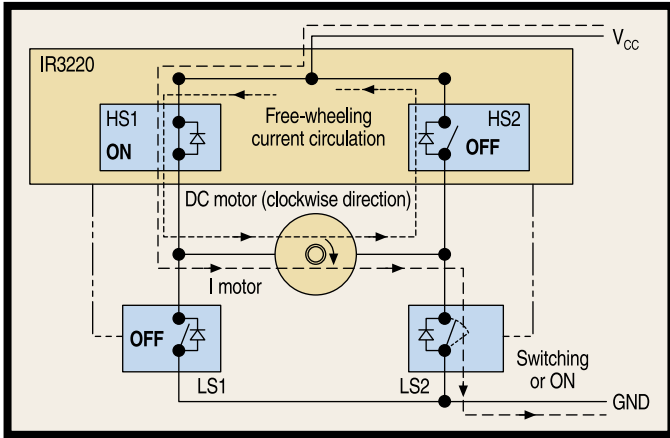

Fig. 1. IR3220 H-bridge motor drive architecture.

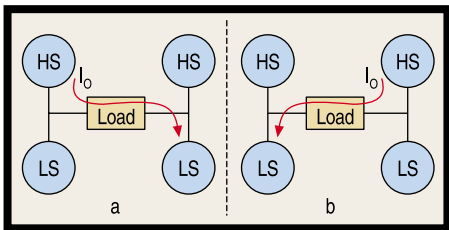

Fig. 2. Basic H-bridge operation: (a) One pair of transistors drive the load; (b) the other switches in.

### Shoot-Through Protection

Fig. 4, on page 20, shows the shoot-through prevention circuit details. Each leg's shoot-through protection takes advantage of the switching time difference between the LS MOSFET and the HS switch. Because of its charge pump circuit, the HS switch has slow turn-on/turn-off times com-

pared with the direct drive of the LS MOSFET. Therefore, when IN 1(2) goes high, the complemented signal turns off the LS MOSFET while the charge pump circuit hasn't turned ON the HS switch. When IN 1(2) goes low, the HS switch turns-off slowly and the LS MOSFET doesn't turn on again until its  $V_{ds}$  decreases to 2V (back to its

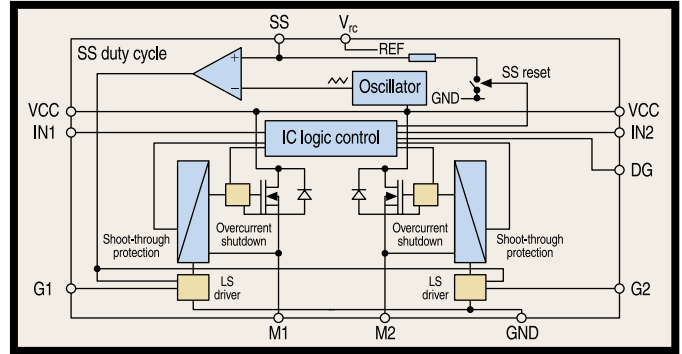
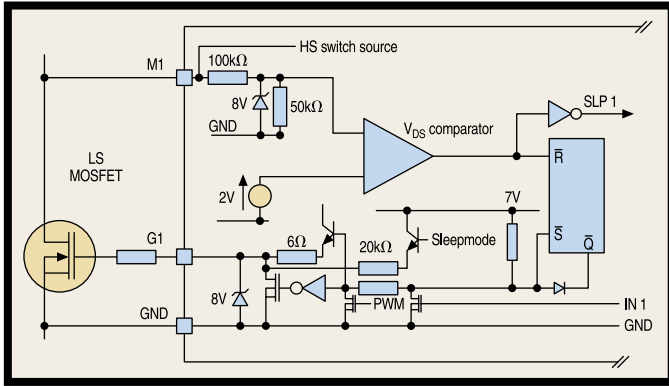

Fig. 3. Circuitry in the IR3220 that drives and protects the integrated HS switches and separate the LS switches. Control functions such as undervoltage lockout, non-braking mode, temperature protection, and the diagnostic feedback are contained here.



**Fig. 4.** IR3220's shoot-through prevention circuit.

quiescent ON state). This technique provides a self-adaptive deadtime circuit with no time-dependent elements.

The core of the shoot-through circuit consists of an RS flip-flop and a voltage comparator. This configuration stores the request for HS turn-on and then resets it when it's fully OFF (i.e.,  $V_{M1} - V_{Gnd} < 2V$ ). The LS driver features a low consumption "Sleep Mode Pull-up" for the quiescent ON state. Although the PWM signal is sent to both LS MOSFETs at the same time, the leg with the IN input at 0V is the only one that cycles its LS MOSFET.

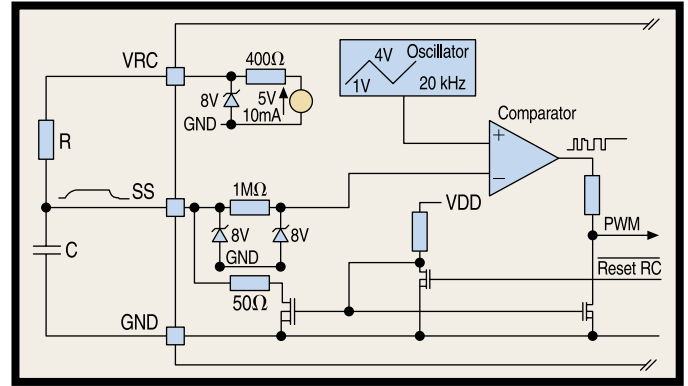

**Fig. 5.** Soft-start sequence circuit.

The SS sequence (Fig. 5) limits inrush current and provides a smooth and low-stress speed ramp-up. This block generates the PWM signal for switching start-up. It consists of a 20 kHz oscillator, voltage comparator, and RC charge/discharge circuit. It compares a 3V symmetrical sawtooth with the SS pin voltage and the PWM signal sent to the LS MOSFETs. The sawtooth goes from 1V to 4V, so the SS pin produces a duty cycle from 0% ( $SS < 1V$ ) up to 100% ( $SS > 4V$ ). The SS pin is normally the central point of an RC network powered by the  $V_{RC}$  pin. It implements



**Photo 1.** A 6A H-bridge control circuit in a 25 mm × 21 mm footprint.

a discharge circuit to reset and hold the SS pin at a low level while the H-bridge is off.

Setting one of the IN 1(2) pins high activates the corresponding leg of the H-bridge (the HS switch turns on and the LS MOSFET turns off), releasing the discharge circuit. The SS voltage increases slowly, resulting in a smooth duty-cycle variation at the gate of the

LS MOSFET. Thus, the switching waveform goes from 0% to 100% duty cycle, offering a low-stress ramp-up to its load. Fig. 6, on page 22, shows an example of SS sequence waveforms.

**Application Example**

The layout in Photo 1 corresponds to a 6A dc motor drive on a p. c. board less than 1 in.<sup>2</sup>. The IRF7484 n-channel MOSFET was developed for the companion LS switches. This 40V, 8-mΩ (typical), 10 mΩ (max) MOSFET is housed in an SO8 package. The 10 mΩ of the LS switch and the 12 mΩ (maximum) of the integrated HS switch make this an efficient motor drive for 6A applications.

The IR3220 reference design has four power MOSFETs with less than 22mΩ on-resistance in an H-bridge topology. The IR3220 can drive low-cost, cable-driven window-lift systems (Photos 2 and 3).



**Photo 2.** A window-lift dc motor with an IR3220 reference kit on the housing.

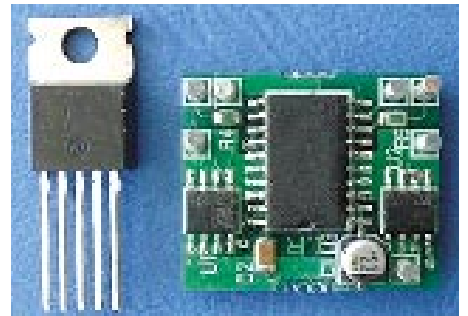

**Photo 3.** A TO-220/5-pin intelligent power switch (IPS) package (left) compared to the IR3220 reference kit (right). The IPS is a 25-mΩ high side switch with integrated circuitry.

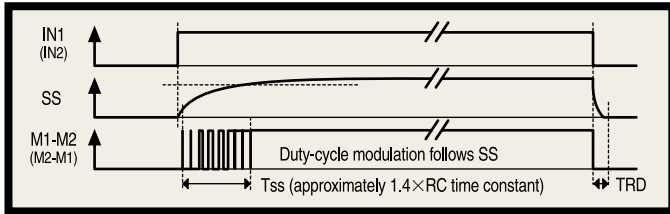

**Fig. 6.** Soft-start sequence waveforms.

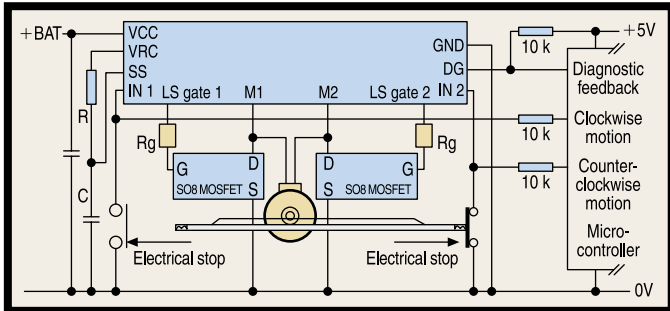

**Fig. 7.** The IR3220 directly interfaces to a microcontroller and drives dc motors up to 80W in forward, reverse, and braking mode.

Fig. 7 shows an IR3220 interfacing with a microcontroller, driving dc motors up to 80W in forward, reverse, and braking mode. A motor drive usually handles a considerable

amount of power, so it's prone to problems associated with high power dissipation and high operating temperature related to motor deficiencies. Designing discrete circuitry to handle these common problems can become complex and may not provide the most space-efficient design. Putting protective circuits within an H-bridge controller IC minimizes the danger of catastrophic failures and allows quick design implementation and verification.

The IR3220 H-bridge solution simplifies the designs by minimizing thermal design and eliminating the need of heatsinking. The reference design uses a low-cost FR-4 p. c. board and operates within the 165°C limit the devices can handle. The Sleep mode that switches the IC to low-current consumption mode (10 mA typical) and a soft switching ramp-up for both directions eliminate the conditions that create the highest power dissipation.

This design can protect itself and its associated motor. It protects against short-circuits and load dump conditions, motor problems and safety related conditions. Overcurrent protection and overtemperature shutdown protect the system during irregular conditions. Plus, it can restart itself and resume operation.

**PETech**

For more information on this article,  
CIRCLE 331 on Reader Service Card