

Digital Signal Controller Based Automatic Transfer Switch

by

Venkat Anant
Senior Staff Applications Engineer
Freescale Semiconductor, Inc.

Abstract: An automatic transfer switch (ATS) enables backup generators, DC to AC inverters, redundant UPS or other AC power sources to be used for a single load. An ATS is recommended when no downtime from a power outage can be tolerated. Traditionally, an ATS used a hardware zero cross detector coupled with a microcontroller to achieve synchronization between power sources. While this approach works when the power is clean, the presence of noise and harmonics in the power sources can trigger spurious zero cross detection. This leads to improper synchronization resulting in a phase discontinuous transfer. The large loop currents that circulate can destroy not only the ATS but also expensive equipment.

This paper will explore notch filtering and correlation based techniques and the merits of implementing it in low cost Digital Signal Controllers (DSC) that will enable seamless transfer between power sources. Such techniques were not possible to implement in low cost microcontrollers as they are not designed to execute numeric intensive algorithms. Furthermore, with DSCs a hardware zero cross detector is not required. A DSC based solution improves reliability, functionality, maintainability and fault tolerance while reducing system cost.

I. INTRODUCTION

It is well known that disturbances occur in power systems. These disturbances are due to various natural causes such as lightning as well as man made noise that manifest itself as high frequency noise, impulse noise and low frequency harmonics. These conditions affect the power distribution system that exists within buildings.

Back up power is now used in critical applications across every industrial sector. With any kind of AC system that contains more than one power source, it becomes essential to have a scheme that enables a transition among the various power sources. In the past, manual transfer switches were used when the power went down to transfer power to another source. In some non-critical applications, this is acceptable. However, for critical applications, an ATS is essential. An ATS enables backup generators, DC to AC inverters, redundant UPS or other AC power sources to be used for a single load. An ATS is required when no downtime from a power outage can be tolerated. Even in non-critical applications, when transfer needs to be effected between power sources without operator intervention, an ATS is required. See Figure 1 for a functional diagram of an ATS.

DIGITAL SIGNAL CONTROLLER BASED AUTOMATIC TRANSFER SWITCH

by Venkat Anant

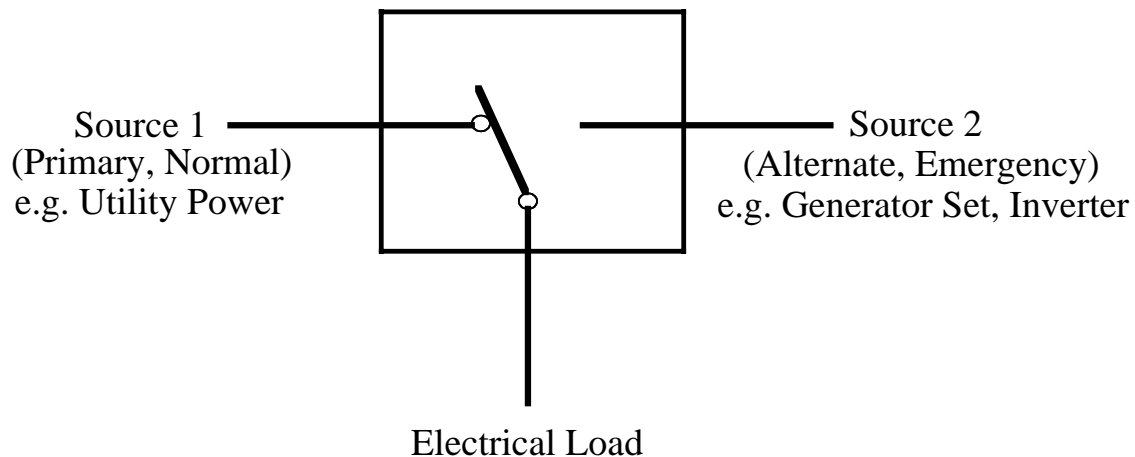

Figure 1: Automatic Transfer Switch

II. PRACTICAL CONSIDERATIONS

ATS systems are used to provide continuous power to the load by automatically transferring between two or more sources when the main source is down or out of tolerance. An ATS automatically disconnects the faulty source and connects the load to another source. Some practical considerations should be taken into account when ATS systems are used, such as [1]:

- **Voltage:** The voltage regulation of the alternate source should be within the permissible range. In case the alternate source is a generator, a voltage regulator unit is needed to automatically control the excitation of the generator, and hence the output voltage. In a DC to AC inverter, the voltage is controlled to match the requirements.
- **Frequency:** The frequency of the alternate source needs to be regulated. In a generator set, frequency is determined by the speed of the driving engine. Closed loop speed control is used to regulate the generator frequency to supply the load at the standard frequency. An inverter normally operates at a fixed output frequency (50 Hz or 60 Hz according to the standards).
- **Synchronization:** Before transferring power through the ATS, the sources need to be at the same voltage, phase sequence and phase shift.

In typical ATS systems, synchronization between sources is achieved by monitoring the zero cross transitions. The circuitry typically includes a low pass filter that conditions the signal followed by a comparator circuit. The output of the comparator is fed to an input capture pin of a microcontroller. The software triggers an interrupt at edge transitions which indicates that the signal has gone through a zero crossing. By tracking the zero crossings, synchronization between the power sources is achieved.

This technique works well when the sources deliver clean power. However, this is often not the case. As stated earlier, signals are corrupted with noise and harmonics. Harmonics come into play in cases when there is an electro-dynamic system (such as an elevator) in the vicinity of the ATS.

DIGITAL SIGNAL CONTROLLER BASED AUTOMATIC TRANSFER SWITCH

by Venkat Anant

While the input low pass filter rejects noise, it cannot reject (low frequency) harmonics that are close to the fundamental frequency. This results in spurious zero cross detections. This problem is often handled by software that “expects” zero crossings at regular intervals. Any detection that falls outside a window of tolerance of that expectation is deemed spurious and rejected. By monitoring several zero crossings, and averaging the results, synchronization may be achieved. However, the presence of harmonics creates so many zero crossings that it is sometimes difficult to estimate the true zero crossings due to the fundamental frequency from the spurious zero crossings. Figure 2 shows a single cycle of a primary signal at 60 Hz with the first two harmonics at 120 Hz and 180 Hz. The signal is sampled at 3000 Hz.

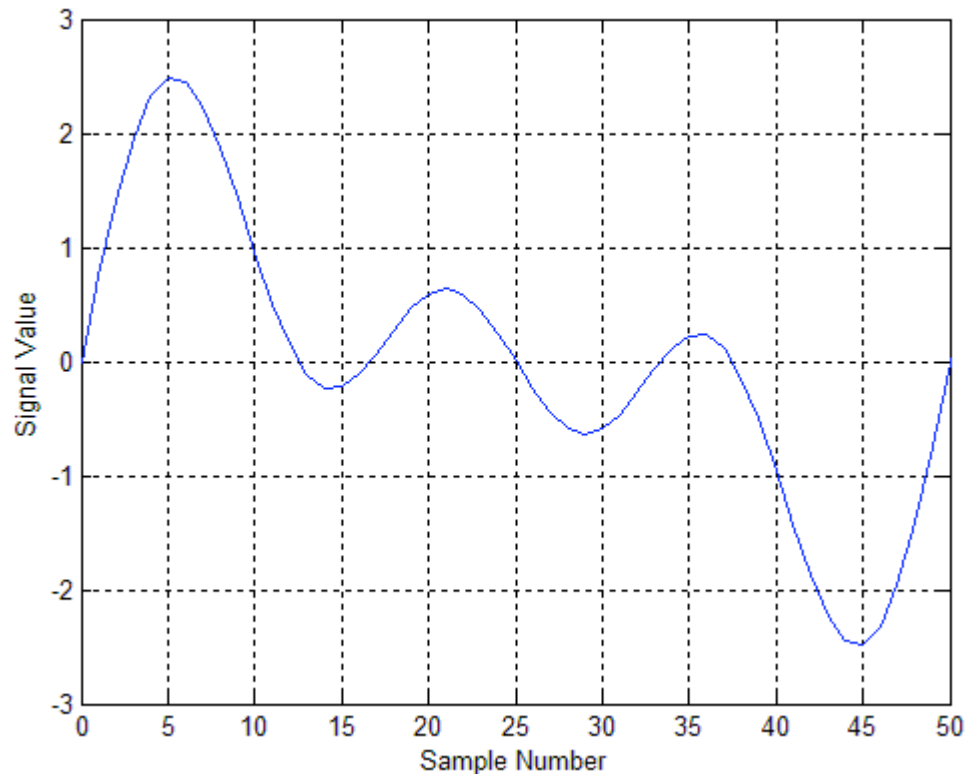

Figure 2: Example of a signal with harmonics

As you can see, there are a number of zero crossings within a cycle. An estimate of synchronization based on zero crossing may result in a phase discontinuous transfer of the ATS. The large loop currents that result may destroy the ATS and expensive equipment. Furthermore, critical loads will be dropped.

III. NOTCH FILTERING

An accurate estimate of zero crossing has led to a lot of research in the field of zero crossing noise reduction [2]. The major approaches to the problem have at least one of the following undesired characteristics:

- Specialized low pass filter

DIGITAL SIGNAL CONTROLLER BASED AUTOMATIC TRANSFER SWITCH

by Venkat Anant

- Dedicated comparator circuitry
- Slow dynamic response
- Calculation time that represents a delay
- Phase shift of the primary signal

It is desirable to have a solution that does not exhibit any of these shortcomings. Any specialized hardware solution increases the cost of the system. Moreover, adding a low pass filter introduces a phase shift of the primary signal. This phase shift needs to be compensated in an ad hoc manner which leads to a heuristic solution. Furthermore, the calculations need to be done without introducing any delay in the execution of the algorithm.

A notch filter contains one or more deep notches or, ideally, perfect nulls in its frequency response characteristic. Notch filters are useful in many applications where specific frequency components must be eliminated. For example, instrumentation systems require that the power line frequency of 60 Hz and its harmonics be eliminated. In this application, we are interested in eliminating all signal components except the 60 Hz primary signal. To retrieve the primary signal embedded with the harmonics, a simple scheme as illustrated in Figure 3 can be used. Care must be taken that the primary signal does not go through any phase shift in the process.

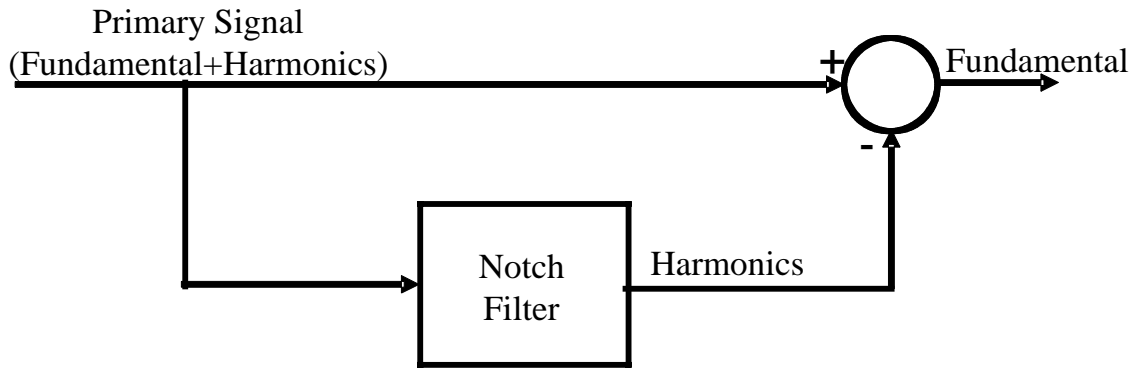

Figure 3: Filtering Scheme

To create a null in the frequency response of a filter at a frequency ω_0 , we simply introduce a pair of complex-conjugate zeros on the unit circle at an angle ω_0 [3]. That is, $z_{1,2} = e^{\pm j\omega_0}$. Thus the system function for an FIR notch filter is simply

$$\begin{aligned} H(z) &= b_0(1 - e^{j\omega_0} z^{-1})(1 - e^{-j\omega_0} z^{-1}) \\ &= b_0(1 - 2\cos\omega_0 z^{-1} + z^{-2}) \end{aligned}$$

Figure 4 shows the frequency response of an FIR notch filter having a null at $\omega = 0.04\pi$ which corresponds to 60 Hz at a sampling frequency of 3000 Hz. A problem with the FIR notch filter is that the notch has a relatively large bandwidth, which means that other frequency components around the desired null are severely attenuated. Furthermore, higher frequencies are actually amplified. The phase response too is unacceptable. Referring to Figure 3 we note that only the primary component needs to be notched out. Also, all the other frequency components need to pass through without any change in magnitude and phase. To reduce the bandwidth of the null, a

DIGITAL SIGNAL CONTROLLER BASED AUTOMATIC TRANSFER SWITCH

by Venkat Anant

longer FIR filter may be designed. However, this leads to increased computation and is not desirable. In addition, a longer FIR filter would not address the issue of phase response.

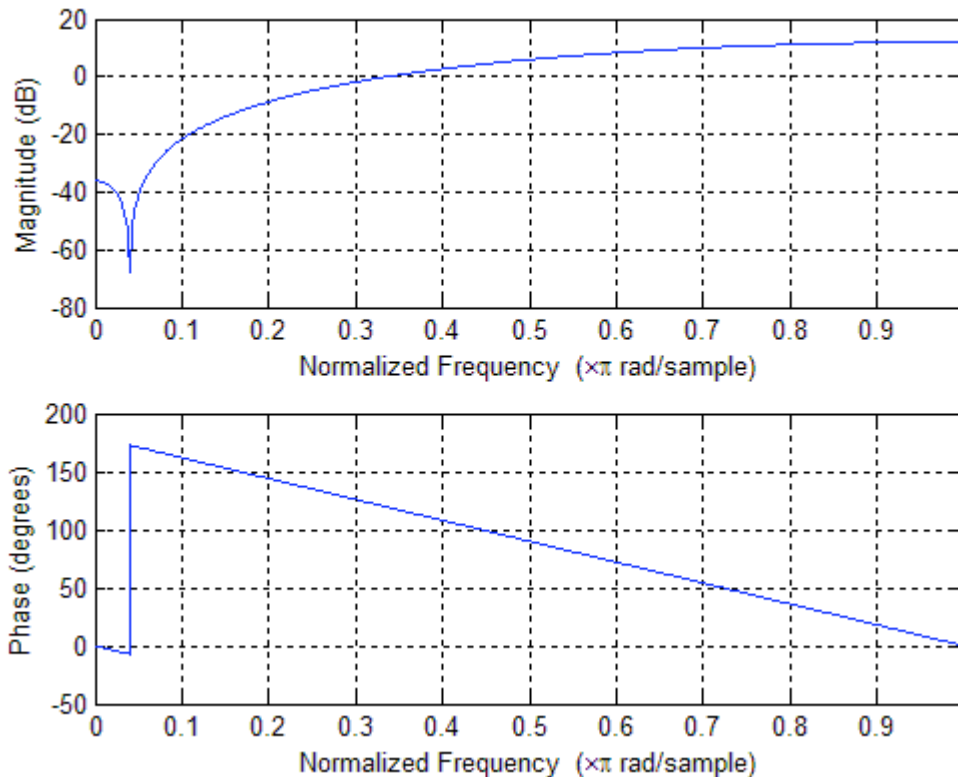

Figure 4: FIR Frequency Response

An attempt to improve the frequency response characteristic can be made by introducing poles in the system function. Suppose that we place a pair of complex-conjugate poles at $p_{1,2} = re^{\pm j\omega_0}$. The effect of the poles is to introduce a resonance in the vicinity of the null and thus to reduce the bandwidth of the notch. The system function for the resulting filter is

$$H(z) = b_0 \frac{(1 - 2\cos\omega_0 z^{-1} + z^{-2})}{(1 - 2r\cos\omega_0 z^{-1} + r^2 z^{-2})}$$

The frequency response of the filter is plotted in Figure 5 for $\omega = 0.04\pi$ and $r = 0.99$. When compared with the frequency response of the FIR filter in Figure 4, we note that the effect of the poles is to reduce the bandwidth of the notch. All signals components, except the fundamental, will pass through the notch filter without any change to their magnitude or phase. This indeed is elegant as the output in Figure 3 will be the retrieved fundamental signal at 60 Hz, as desired.

Figure 6 shows the results of running a harmonically corrupted input through the system described in Figure 3. A traditional zero cross detector will not be able to accurately estimate the true zero crossings due to the harmonics. However, with clean signals, the software can monitor sign changes in the filter output and synchronize the two power sources. It is important to note that the recovered signal is an almost exact replica of the original because of the frequency response of the notch filter. This effectively addresses the problem of phase shift of the primary

DIGITAL SIGNAL CONTROLLER BASED AUTOMATIC TRANSFER SWITCH

by Venkat Anant

signal that was mentioned earlier. No ad hoc scheme to adjust for a phase delay due to a nonlinear phase response is required in this case.

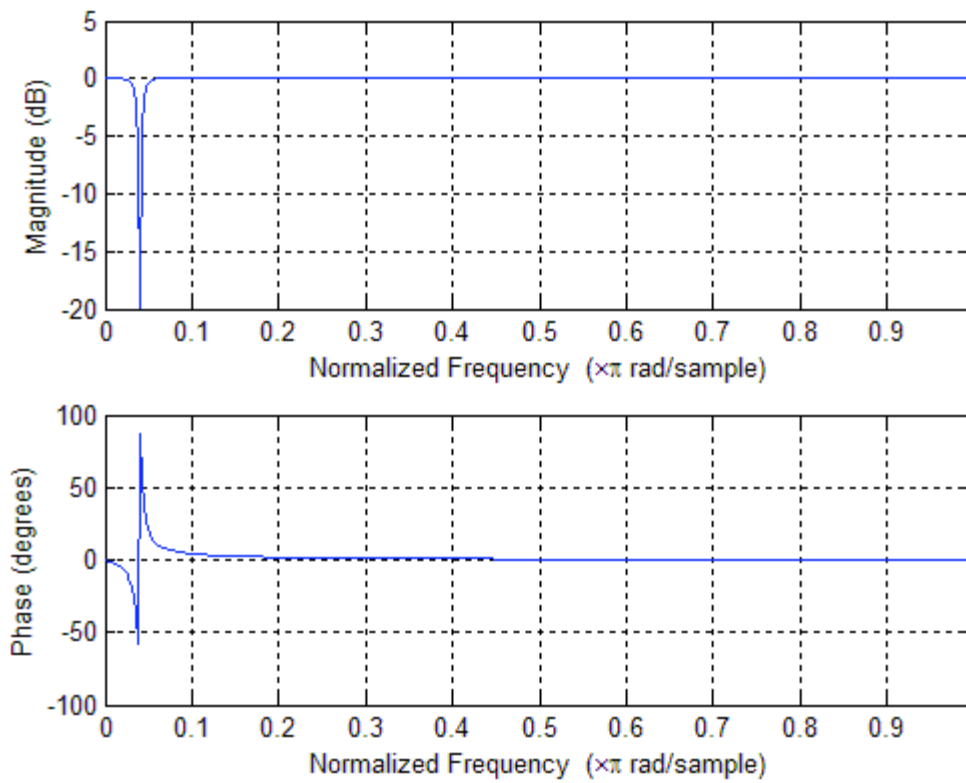

Figure 5: Notch Filter Frequency Response

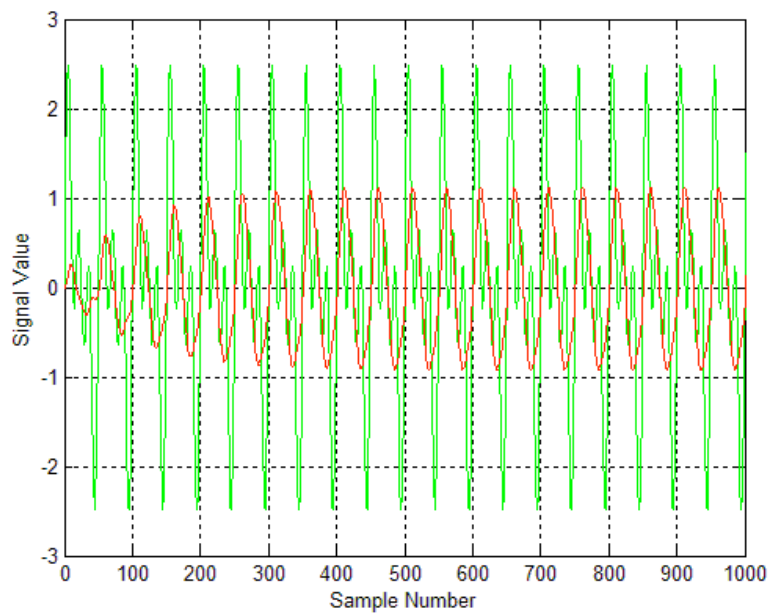

Figure 6: Filtered Signal

IV. CORRELATION BASED SYNCHRONIZATION

In the previous section we highlighted how the zero cross issue is effectively dealt with by running the primary and alternate sources through a system as described in Figure 3. In practice, the alternate source is maintained at a slightly different frequency from the primary source. This is by design so that their phase relationship varies with time. If they were at the same frequency, their phase relationship would never vary and synchronization would never be possible.

By tracking the software zero cross of the filtered signals, synchronization can be achieved. However, this is a bit complicated as software has to monitor the zero crosses from two signals and then decide on the synchronization point.

A simple method to achieve synchronization is by correlating the two filtered signals. As noted before, the fundamental components have been retrieved after the filtering process. Since they are periodic in time, the correlation sequence will also be periodic. In fact, the period of the correlation sequence is equal to the beat frequency of the two signals. Figure 7 gives an illustration of the above property. The two primary signals are chosen as 60 Hz and 61 Hz respectively. The correlation waveform is periodic at 1 Hz because the signals “come together” every second. The zero crossings of this waveform correspond to 90 and 270 degrees out of phase, the minimum points represent 180 degrees out of phase and the maximum points represent the instances when the signals are in phase and synchronization is achieved. Monitoring the correlation sequence of the cleaned up signals is an easier way to achieve synchronization than monitoring several zero crossings of two signals.

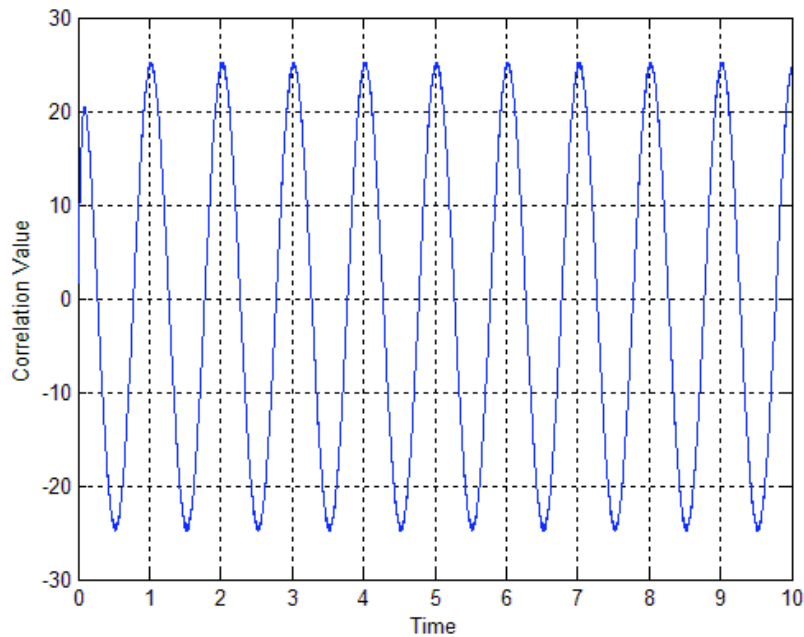

Figure 7: Primary and Alternate Source Synchronization

DIGITAL SIGNAL CONTROLLER BASED AUTOMATIC TRANSFER SWITCH

by Venkat Anant

In practice, the primary and alternate source frequencies are closer together so synchronization occurs less frequently than 1 second. An advantage of having the signals closer together is that the sources are closer in phase for a longer time interval. This allows for the actual switching hardware to overcome inertia and make the transition. A 1 second beat frequency in the example is chosen merely to show several cycles where synchronization is possible.

IV. DIGITAL SIGNAL CONTROLLER SOLUTION

In an increasingly competitive market that is driven by cost and time-to-market, low-cost microcontrollers have been used in embedded systems. These processors were designed to control the entire system including all the supervisory tasks in addition to handling the user interface. With limited processing power, only simple control algorithms could be executed limiting their functionality. Digital Signal Processors (DSP) on the other hand are number crunching devices that were typically used in high end applications like telecommunications and audio/video processing that required a lot of processing in a short amount of time. However, they do not have the control capabilities of microcontrollers.

ATS systems are typically designed with microcontrollers that have all the peripherals to handle the supervisory tasks. However, the numeric capability of such microcontrollers are lacking. The core is built with a single bus that carries the program and data from memory. Furthermore, a multiplier, if present, takes several cycles to execute. There is no support for parallel operation within an instruction. The compilers too do not support fractional arithmetic. For these kinds of reasons, only simple algorithms can be executed in a microcontroller based ATS. This is the reason why such a solution relies on external circuitry to reduce noise and to generate a zero cross signal, increasing cost while not being as reliable.

A single chip that incorporates the advantages of microcontrollers and DSPs is clearly the preferred solution. A digital signal controller (DSC) is such a device that is designed for both efficient DSP and a variety of controller operations in a single chip. By combining the processing power of a DSP with the programming simplicity of a microcontroller, it can provide high speed, low-cost, and easy to design solutions. DSCs have taken away some of the market share that belonged to microcontrollers because they provide the best of both worlds.

Let us take a brief look of a typical DSC offered by Freescale Semiconductor, Inc. to understand the type of architecture and system integration available [4]. See Figure 8. The core is based on a dual Harvard-style architecture consisting of three execution units operating in parallel, allowing as many as six operations per instruction cycle. The MCU-style programming model and optimized instruction set allow straightforward generation of efficient, compact DSP and control code. The instruction set is also highly efficient for C Compilers to enable rapid development of optimized control applications.

In addition, a variety of peripherals is provided thereby enhancing performance, reducing applications cost and promoting ease of product development. The blocks in red show the available on chip and off-chip memory configuration options. On-chip flash enables true stand alone system development as there is no need for external memory to operate. The blocks in gold show the communication options available for inter-processor communication as well as

DIGITAL SIGNAL CONTROLLER BASED AUTOMATIC TRANSFER SWITCH

by Venkat Anant

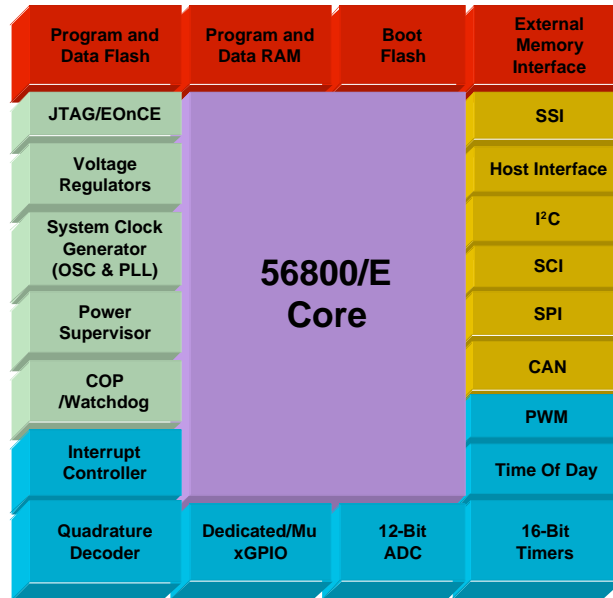

Figure 8: Freescale 56800/E Integrated Peripherals

off-chip peripheral integration. The blocks in blue show general purpose peripherals typically found in microcontrollers. The blocks in green show dedicated resources required for safe operation as well as cost savings by not requiring external circuitry for system debugging, power supervision, voltage regulation, and system reset.

Some benefits of the core include the following:

- Efficient 16-bit DSC engine with dual Harvard architecture
- Single cycle 16_16-bit parallel Multiplier-Accumulator (MAC)
- Four 36-bit accumulators, including extension bits
- Arithmetic and logic multi-bit shifter
- Hardware DO and REP loops
- Three internal address buses
- Four internal data buses
- Parallel instruction set with unique DSP addressing modes
- Instruction set supports both DSP and controller functions
- DSP and MCU functionality in a unified, C-efficient architecture
- MCU style addressing modes and instructions for compact code
- MCU style software stack support
- Architectural support for 8-, 16-, and 32-bit single-cycle data fetches
- JTAG/EOnCE debug programming interface
- Proven to deliver more control functionality with a smaller memory footprint than competing architectures

DIGITAL SIGNAL CONTROLLER BASED AUTOMATIC TRANSFER SWITCH

by Venkat Anant

A DSC thus lends itself very well to an ATS application. With a high performance core and comprehensive set of peripherals you get a formidable solution. It not only simplifies the design while reducing power consumption and system costs, it also reduces the time-to-market which is critical in a competitive market.

V. CONCLUSION

A new technique that uses notch filtering and correlation based techniques has been proposed that will enable seamless transfer between two power sources using an ATS. A single chip Digital Signal Controller (DSC) that incorporates the advantages of microcontrollers and DSPs is also reviewed. By combining the processing power of a DSP with the programming simplicity of a microcontroller, it can provide high speed, low-cost, and easy to design solutions. The proposed techniques were not possible to be implemented in low cost microcontrollers as they are not designed to execute numeric intensive algorithms. Furthermore, with DSCs a hardware zero cross detector is not required. A DSC based ATS improves reliability, functionality, maintainability and fault tolerance while reducing system cost.

REFERENCES

- [1] Ashour, H., Automatic Transfer Switch (ATS) using programmable logic controller (PLC), *Mechatronics*, 2004, Proceedings on the IEEE International Conference on ICM '04, June 2004, Pages: 795-799.
- [2] Vainio, O., Noise Reduction in Zero Crossing Detection by Predictive Digital Filtering, *IEEE Transactions on Industrial Electronics*, Volume 42, Issue 1, Jan 1995, Pages: 286-295.
- [3] Proakis, J. G., Manolakis D., *Digital Signal Processing: Principles, Algorithms and Applications*, Prentice Hall, 3rd Edition, 1995.
- [4] DSP56800E 16-bit DSP Core Reference Manual.