



S I L I C O N L A B O R A T O R I E S

Implementing High Speed
Isolation Barriers in SMPS with Primary
Side Digital Control

October 2006

Keith Coffey — Silicon Laboratories, Inc.

Agenda

- ◆ Applications
- ◆ Regulator approvals
- ◆ Key terms
- ◆ Isolated SMPS with Digital Control
- ◆ Update time for digital SMPS
- ◆ Isolation technology
- ◆ Radiated emissions for RF isolator
- ◆ Opto-coupler limitations
- ◆ GMR limitations
- ◆ Technology summary



Applications

◆ Example circuit applications:

- Isolation
- Level shifting
- Ground loop elimination

◆ Example end applications:

- AC-DC and DC-DC switching supplies
- Motor control systems
- Isolated analog data acquisition
- Plasma TVs
- Ethernet/CAN networks
- Isolated point-to-point communications
- UPS systems
- Operator interface controls

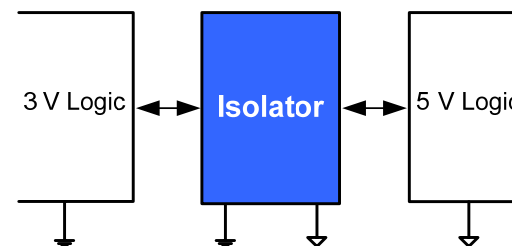

Level Shifting & Ground Loop Elimination

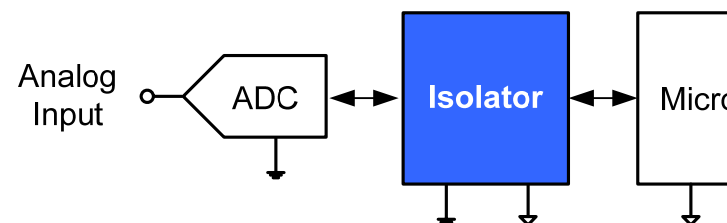

Isolated Analog Sampling

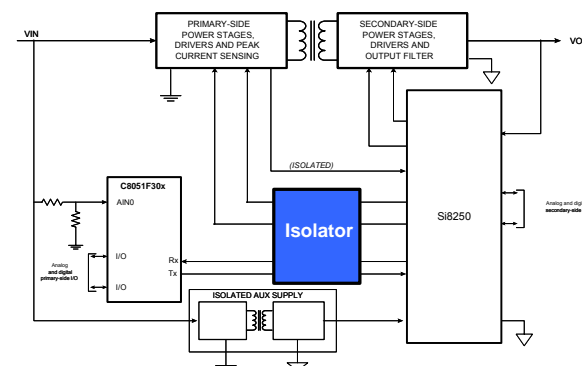

Digitally Controlled Power



Regulator Approvals

- ◆ 60950 — System level certification for information technology equipment
- ◆ 61010 — System level certification for test & measurement instruments
- ◆ Underwriters Laboratories — USA
 - UL1577
 - 2500 V_{RMS} (1 minute)
 - Site inspections
- ◆ CSA International — Canada
 - Component Acceptance Notice #5A
 - 2500 V_{RMS} (1 minute)
 - Site inspections
- ◆ IEC (International Electrotechnical Commission) — International, most stringent
 - IEC 60747-5-2
 - 2500 V_{RMS} (1 minute)
 - Site inspections
 - Quality, reliability and documentation inspections



Key Terms

◆ Propagation delay

- The time it takes a signal to transition across the barrier.

◆ Creepage

- The distance along the insulating surface an arc may travel.

◆ Clearance

- The shortest path through air that an arc may travel.

◆ Safety extra-low-voltage (SELV)

- Voltage less than $30 V_{RMS}$ (42.4 V peak) or 60 V DC.

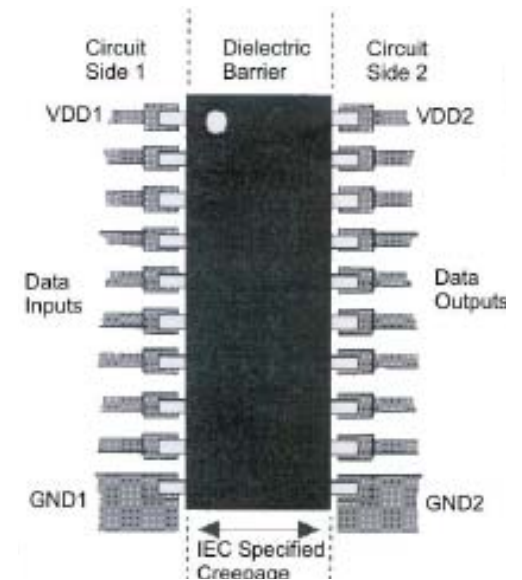

Key Terms (continued)

◆ Hazardous (also called “live”)

- Voltage greater than 30 V_{RMS} (42.4 V peak) or 60 V DC.

◆ Rated voltage

- The allowable continuous operating voltage that the manufacturer specifies.

◆ Working voltage

- The highest possible root-mean square value of the ac and dc voltage across insulation when the product is operating at its rated voltage.

◆ Isolation voltage

- Isolation voltage is based on qualification test voltages that stresses the insulation of the product. High-pot (dielectric withstand) tests are performed to determine isolation level for an isolation product.



Key Terms (continued)

◆ **Functional insulation**

- Also called “operational insulation.” Does not protect or isolate against electrical shock but is required for a product to function.

◆ **Basic insulation**

- A single level of insulation that provides basic protection against electrical shock.

◆ **Supplementary insulation**

- An independent insulation that manufacturers apply in addition to basic insulation to reduce the risk of electrical shock in the event of a failure of basic insulation.

◆ **Double insulation**

- Comprises both basic and supplementary insulation.

◆ **Reinforced insulation**

- Is a single insulation system that provides electrical-shock protection equivalent to double insulation.

- ◆ Note: Double, reinforced, and basic insulation are the most important for safety isolation. Double or reinforced insulation is required for voltages ranging from SELV to hazardous.



Isolated SMPS with Digital Control

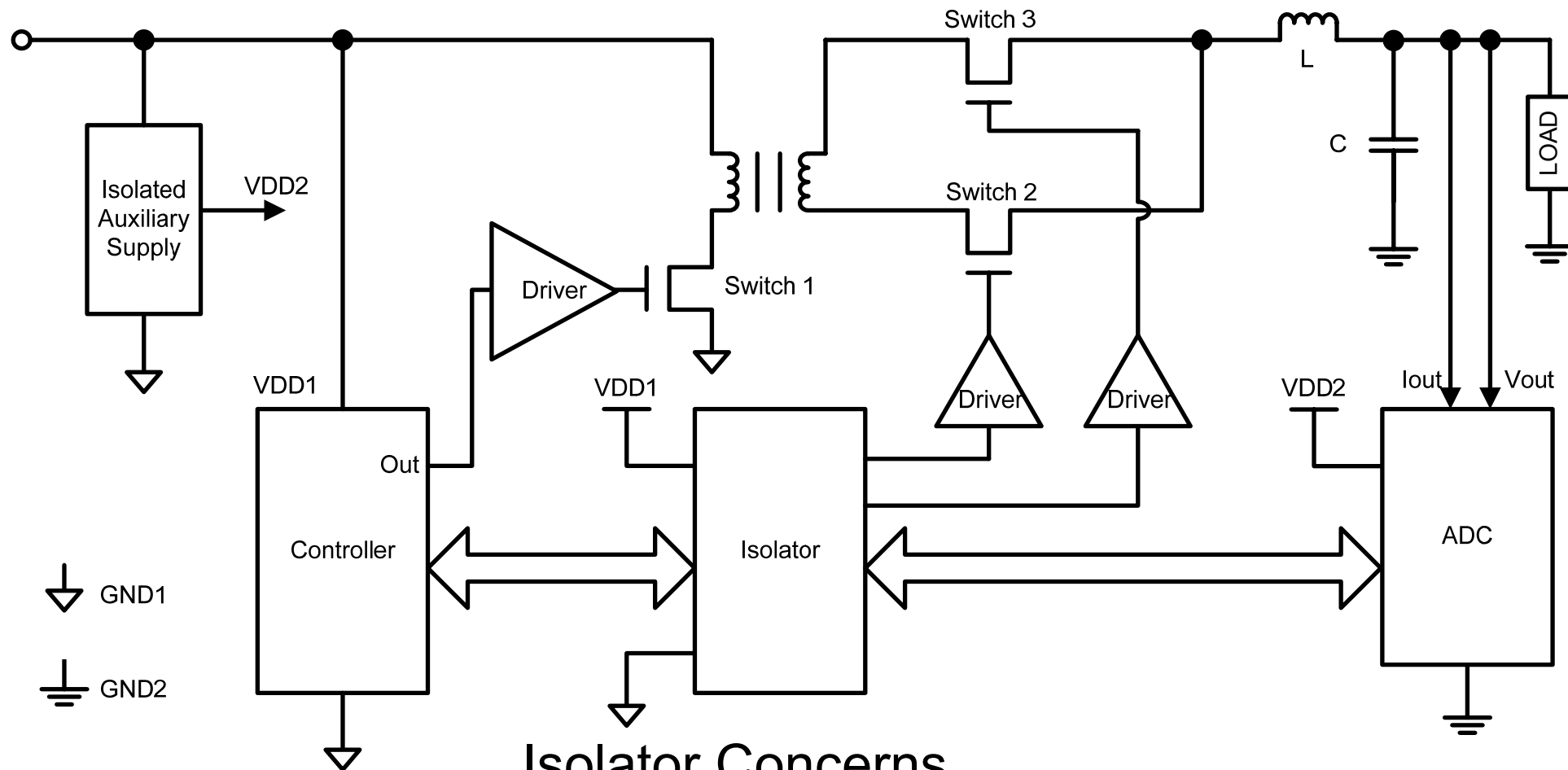

Isolator Concerns

- Greater power efficiency
- Increased system speed
- Greater protection



Update Time for Digital SMPS

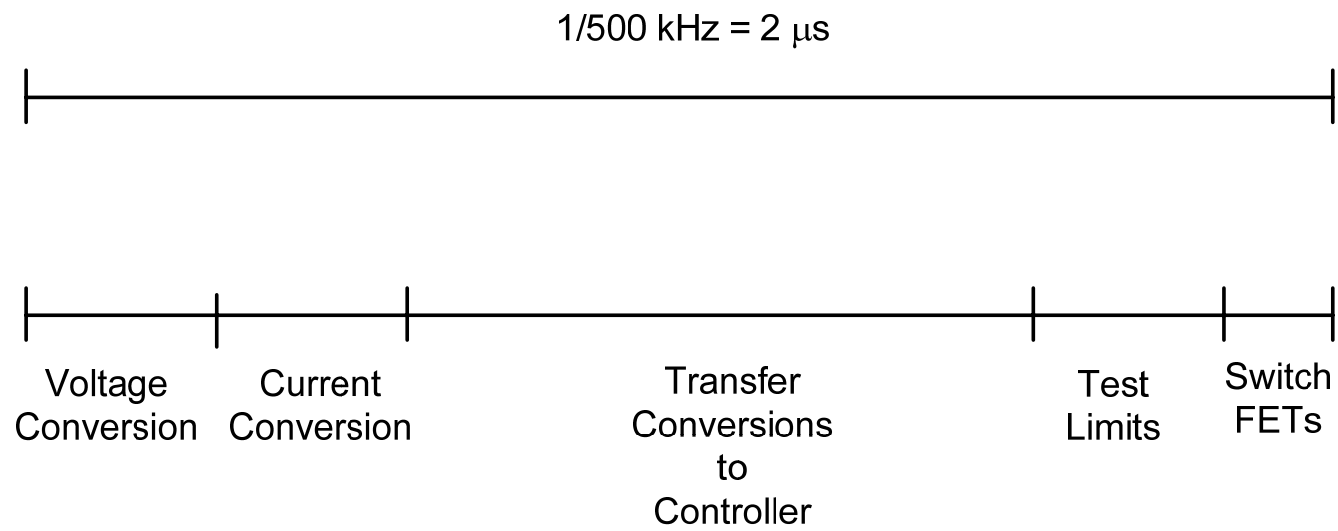

Isolation Technology

◆ Opto-couplers

- Performance degrades at high temp
- Usually only singles per package
- Limited data rate (most 10 Mbps or less)

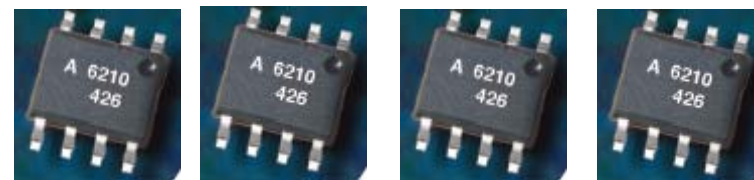

◆ Pulse transformers

- Bulky
- Expensive in cost and real estate
- No dc correctness

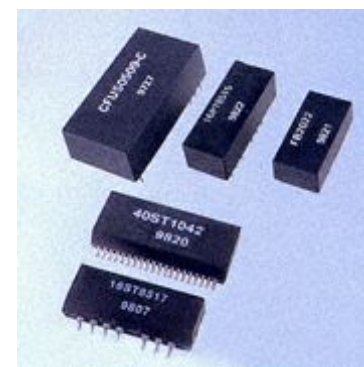

◆ Giant magneto-resistive couplers

- Senses magnetic fields
- Up to 100 Mbps
- Random startup states

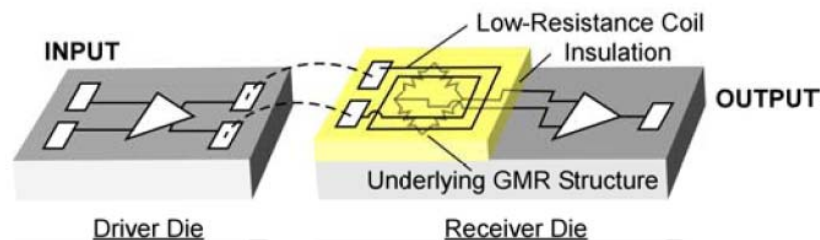

NVE IsoLoop Technology

Isolation Technology (continued)

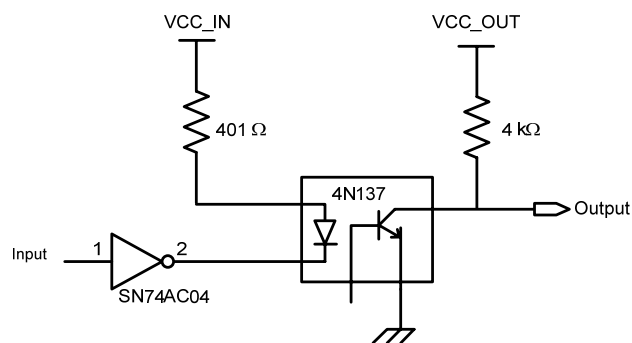

Opto

- ◆ Implements light detection for communications

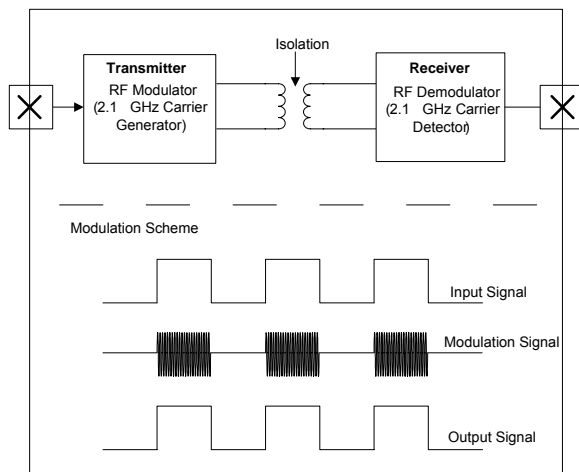

RF

- ◆ Implements RF modulation demodulation scheme to transfer data

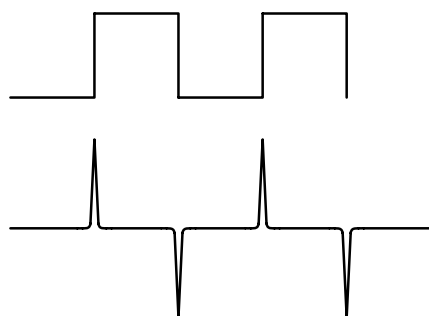

Pulse

- ◆ Implements pulse code demodulation across chip scale transformers



SILICON LABORATORIES

Radiated Emissions for RF Isolator

Frequency (GHz)	Measured (dB μ V/m)	FCC Spec (Part 15) (dB μ V/m)	Compared to Spec (dB)
2.09	70	74	-4
2.17	68.3	74	-5.7
4.21	61.9	74	-12.1
4.34	60.7	74	-13.3
6.32	58.3	74	-15.7
6.51	60.7	74	-13.3
8.67	45.6	74	-28.4



Opto-Coupler Limitations

- ◆ Integration
 - 1 package per multiple channel
 - External components (Rs, Cs, Diodes) required for solution
- ◆ Limited throughput performance
 - Difficulty with increasing data rate/timing requirements, typically <10 Mbps
- ◆ Excessive power consumption and temperature dependence
 - Inefficient electro-optic conversions
 - Sensitive to temperature and variations in supply voltage
 - System performance degrades over time
 - Requires temperature compensation
- ◆ Difficult to use/expensive
 - Opto-couplers are analog in nature
 - Numerous board tweaks
 - Increases design time/costs
 - Digital Couplers are plug and play!

Digital Coupler Solution

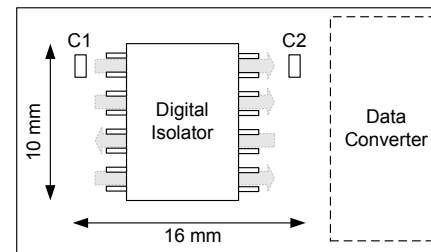

Optocoupler Solution

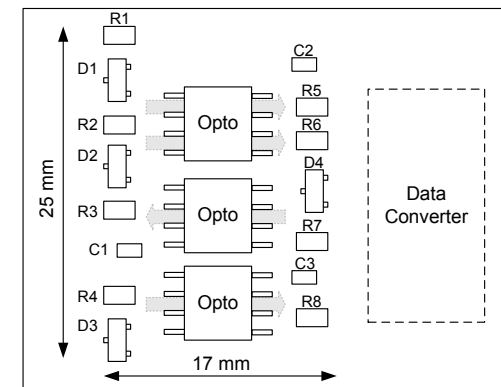

GMR Limitations

Condition	GMR
Power-up/initialization	Output may or may not match the input
Input noise susceptibility	Following a noise spike, output may match the input, may not match the input, or may oscillate
Slow input rise time	Output may transition to correct state, may remain in incorrect state, or may oscillate
Output ringing/overshoot	Excessive overshoot (~1.8 V measured) with 2-3 oscillations



Technology Summary

Parameter	Digital Coupler (RF)	Digital Coupler (Pulse)	Digital Coupler (GMR)	Opto-Coupler (Best Grade)
Max. Data Rate (Mbps)	Up to 150	Up to 100	Up to 100	Up to 50
Power Consumption/ Channel (mA, typ)	12 (5 V, 100 Mbps)	31 (5 V, 90 Mbps)	7*	25*
Supply Voltage (V)	2.375 – 5.5	2.7 – 5.5	2.7 – 5.5	4.5 – 5.5
Temp. Range (°C)	-40 to +125	-40 to +125	-40 to +125	-40 to +85
Prop. Delay (ns)	<10	20	15	22
Pulse-width Distortion (ns)	2	3	3	2
Transient Immunity (kV/μs, min.)	25	25	15/20	10
No. of Channels	4	4	4	2
Protection	Basic/Reinforced	Basic/Reinforced	Basic/Reinforced	Basic/Reinforced
Package	16-Lead Wide Body SOIC	16-Lead Wide Body SOIC	8-Lead SOIC	8-Lead SOIC

* Specifications according to manufacturers' datasheets.



SILICON LABORATORIES



S I L I C O N L A B O R A T O R I E S

Thank You