

Charge Your Battery Faster By Using a USB Port

By Len Sherman, Senior Scientist, Maxim Integrated Products, Sunnyvale, Calif.

Design considerations for battery charging from USB include how fast a device with a discharged battery must operate with full functionality when plugged into a USB port; time allowed for battery charging; power budgeting within USB limits; and the need for ac adapter charging.

One of the best but least-celebrated features of the universal serial bus (USB) standard is that power is supplied from the host to plugged-in USB peripherals. This enlightened change from the serial and parallel ports of the past allows a dramatic increase in the variety of devices that can be conveniently connected to a PC.

In addition to directly powering USB devices, one of the more useful functions to perform with USB power is battery charging.¹ Because many portable devices, such as MP3 players and PDAs, exchange information with PCs, device convenience is significantly enhanced if battery charging and data exchange take place simultaneously and over one cable. Combining USB and battery-powered functionality gives rise to a whole range of “untethered” devices, such as removable web cameras, that operate whether or not they are connected to a PC. In many cases, it’s no longer necessary to include the ever-present and awkward ac adapter or “wall wart.”

USB Power

All USB host devices, such as PCs and notebooks, can source at least 500 mA or five “unit loads” per USB socket. In USB terminology, “one unit load” is 100 mA. Self-

powered USB hubs can also supply five unit loads. Bus-powered USB hubs are guaranteed to supply only 1 unit load (100 mA). According to the USB spec (Fig. 1), the minimum available voltage from a USB host or powered hub at the peripheral end of the cable is 4.5 V, while the minimum voltage from a USB bus-powered hub is 4.35 V. These voltages allow little headroom when charging Lithium (Li-Ion) batteries, which typically require 4.2 V, making charger dropout extremely important.

All devices that plug into a USB port must start out drawing no more than 100 mA. After communicating with the host, the device determines if it can take the full 500 mA.

USB peripheral devices contain one of two receptacles. Both are smaller than the socket found in PCs and other USB hosts. Fig. 2 illustrates the Series B and the smaller Series Mini-B receptacles. Power is taken from pins 1 (+5 V) and 4 (GND) on the Series B, and from pins 1 (+5 V) and 5 (GND) on the Series Mini-B.

Once connected, all USB devices must identify themselves to the host. This is called “enumeration.” Later, we’ll discuss practical exceptions to this rule. In the identification process, the host determines the power needs of the USB devices and allows or denies the device to increase its load from 100-mA maximum to 500-mA maximum.

Simple USB/AC Adapter Charging

Some very basic devices many not want the software overhead needed to sort out and optimize use of the available USB power. If the device load current is limited to 100 mA (termed “one unit load” in USB parlance) any USB host, self-powered hub, or bus-powered hub can power the device. Fig. 3 shows a very basic charger and regulator scheme for such designs.

This circuit charges the battery whenever the device is docked to USB or plugged into the ac adapter. At the same time, the system load is always connected to the battery—

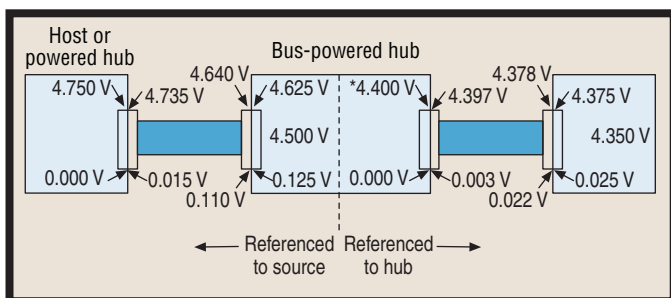

Fig. 1. USB voltage drops (from USB Specification Rev 2.0).

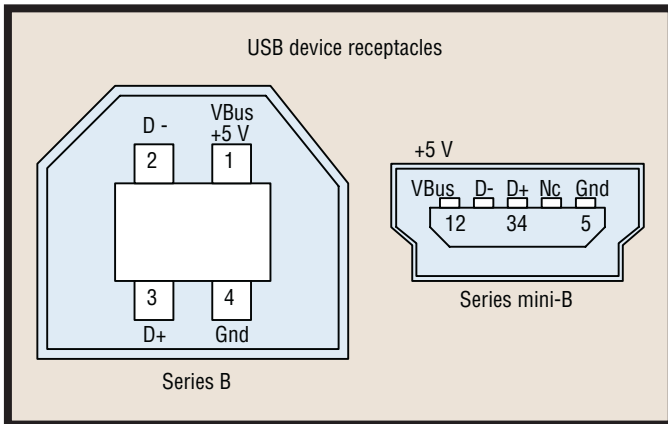

Fig. 2. These receptacles for USB peripherals differ from the large 4-pin sockets found on hosts and hubs. Power and data connection pins are shown.

in this case, through a simple linear regulator (U2)—that can supply up to 200 mA. If the system continuously draws that amount of current while the battery is charging at 100 mA from USB, the battery will still discharge because the load current exceeds the charge current. In most small systems, the peak loads occur only for a fraction of the total operating time. Thus, as long as the average load current is less than charging current, the battery will still charge. When the ac adapter is connected, the charger (U1) maximum current increases to 350 mA. If USB and the ac adapter are connected at the same time, the ac adapter is automatically given precedence.

One characteristic of U1 that is required by the USB spec is that current is never allowed to flow back to a power input from either the battery or another power input. In conventional chargers, this can be guaranteed with input diodes, but the small difference between the minimum USB voltage (4.35 V) and the required Li-Ion battery voltage (4.2 V) makes even Schottky diodes inappropriate. For this reason, all reverse current paths are blocked within the U1 IC.

The circuit shown in Fig. 3 has limitations that may make it inappropriate for some rechargeable USB devices. The most obvious is its relatively low charge current, which translates to long charge time if the Li-Ion battery capacity is more than a few hundred mA-hours. The second limitation occurs because the load (linear regulator input) is always connected to the battery. In this case, the system may not be able to operate immediately upon being plugged in if the battery is deeply discharged since there may be a delay before the battery reaches a sufficient voltage for the system to operate.

Load Switching and Other Enhancements

In more advanced systems, several enhancements are often required in or around the charger. These include selectable charge current to match the current capability of the source (USB or ac adapter) or battery, load switching when power is plugged in, and overvoltage protection. The circuit shown in Fig. 4 adds some of these features by means

of external MOSFETs driven by voltage detectors in the charger IC.

MOSFETs Q1 and Q2 and diodes D1 and D2 bypass the battery and connect the active (USB or ac adapter) power input directly to the load. When a power input is valid, its monitor output (UOK or DCOK) goes low to turn on the appropriate MOSFET. When both inputs are valid, the dc input has precedence; U1 prevents both inputs from being active at the same time. Diodes D1 and D2 prevent reverse current from flowing between inputs via the “system load” power path, while the charger has built-in circuitry to prevent reverse current through the charging path (at BATT).

MOSFET Q2 also provides ac adapter overvoltage protection up to 18 V. An under/overvoltage monitor (at dc) allows charging only when the ac adapter voltage is between 4 V and 6.25 V.

The last MOSFET, Q3, turns on to connect the battery to the load when no valid external power is present. When either USB or dc power is connected, the Power On (PON) output immediately shuts off Q3 to disconnect the battery from the load. This allows the system to operate immediately when external power is applied, even if the battery is deeply discharged or damaged.

When USB is connected, the USB device communicates with the host to determine if the load current can be increased. The load starts out at one unit load and is increased to five unit loads if the host allows it. This 5-to-1 current range can be problematic for conventional chargers (not designed for USB). The problem is that the current accuracy of conventional chargers, though adequate at high current, usually suffers at low current settings because of offsets in the current-sense circuitry. The result can be that the low-range (for one unit load) charge current may have to be set too low to be useful in order to ensure it never exceeds the 100-mA limit. For example, with 10% accuracy at 500 mA, the output would have to be set for 450 mA to ensure it never exceeds 500 mA. That alone is acceptable. However, to ensure the low-range charge current doesn't exceed 100 mA, the nominal current would have to be set at 50 mA, and the minimum could then be 0 mA, which clearly is unacceptable. If USB charging is to be effective in both ranges, sufficient accuracy is needed to allow the maximum possible typical charge current without exceeding the USB limits.

In some designs, system power needs are such that it's impractical to separately power the load and charge the battery with less than the 500-mA USB budget, but doing so from an ac adapter is not a problem. The connection in Fig. 5, a simplified subset of Fig. 4, does this in a cost-effective way. USB power isn't routed directly to the load. Both charging and system operation still take place on USB power, but the system remains connected to the battery. The limitation is the same as in Fig. 3. If the battery is deeply discharged when USB is connected, there may be a delay before the system can operate. However, if dc power is con-

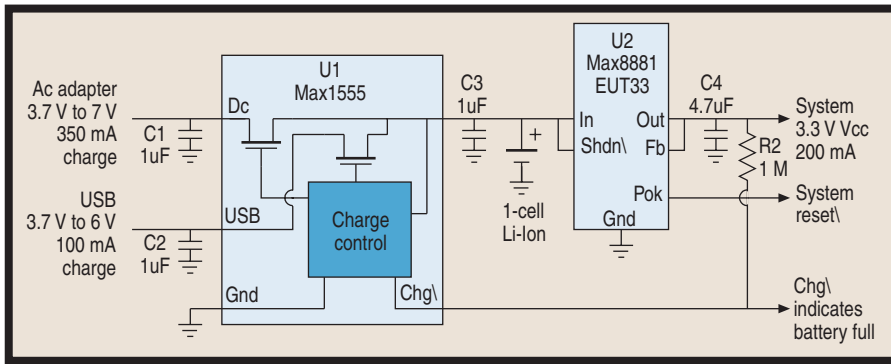

Fig. 3. With simple charging at 100 mA from USB and 350 mA from an ac adapter, no enumeration is needed for the charger because the USB charge current doesn't exceed "one unit load."

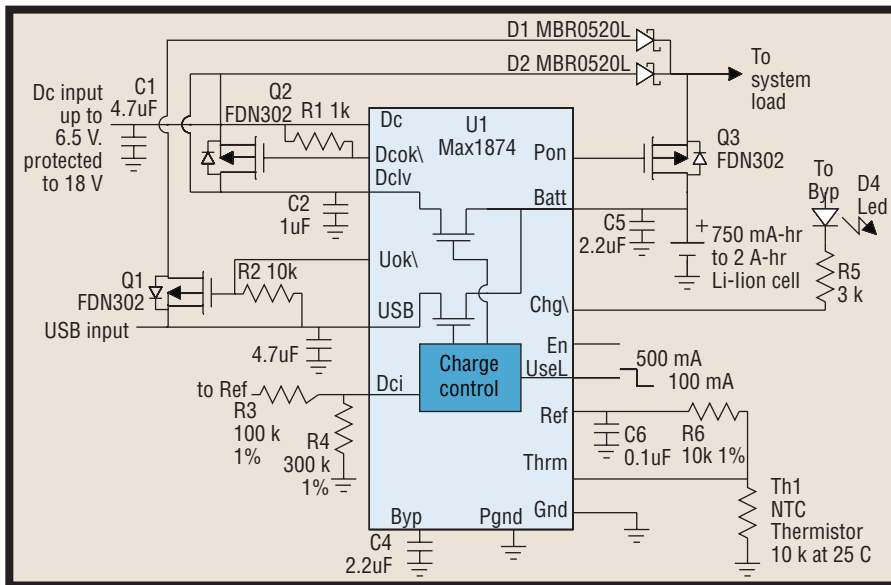

Fig. 4. SOT-23 power MOSFETs add useful features such as overvoltage protection and battery disconnect when external power is applied.

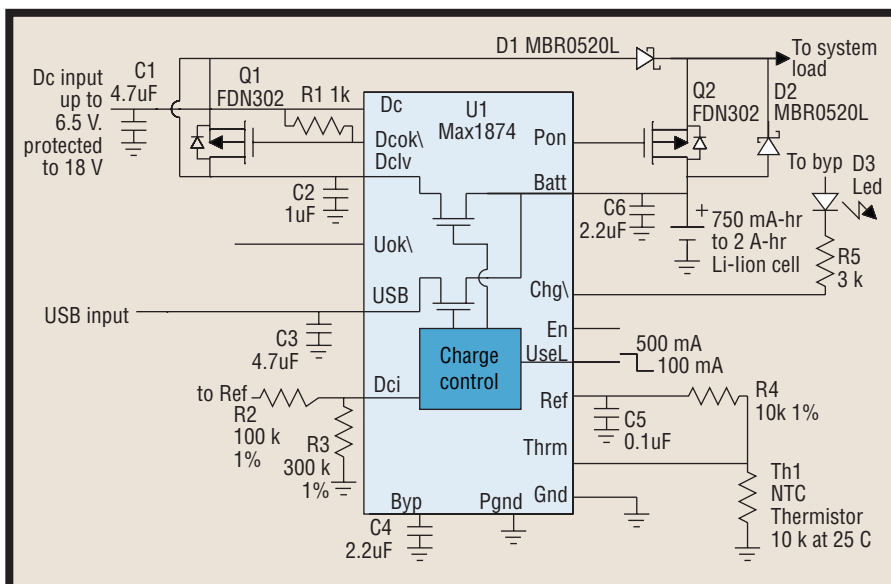

Fig. 5. A simplified design doesn't pass USB power directly to the load, but does so for the dc input.

nected, Fig. 5 operates in the same manner as Fig. 4 with no wait, regardless of battery state because Q2 turns off, passing the system load from the battery to the dc input via D1.

Nickel-Metal Hydride Charging

Although Li-Ion batteries provide the best performance for most portable information devices, Nickel-Metal Hydride (NiMH) cells are still a viable choice in minimum-cost designs. A good way to keep cost low when the load requirements aren't too severe is by using one NiMH cell. This requires a dc-dc converter to boost the typically 1.3-V cell voltage into something the device can use (typically 3.3 V). Because some type of regulator is needed for any battery-powered device, the dc-dc converter is really then only a different—not an additional—regulator.

The connection in Fig. 6 uses an unusual approach to charge the NiMH cell and to switch the system load between the USB input and the battery with no external FETs. The "charger" is actually a dc-dc step-down converter (U1) operated in current limit. It charges the battery with between 300 mA and 400 mA. Though not a precise current source, it has adequate current control for the purpose and can maintain current control even into a shorted cell. An advantage of the dc-dc charging topology over more common linear schemes is efficient use of the limited USB power resource. When charging one NiMH cell at 400 mA, the circuit draws only 150 mA from the USB input, which leaves 350 mA for system use while charging.

Load handoff from the battery to USB is done by diode or-ing (D1) USB power with the boost converter output. When USB is disconnected, the boost converter generates 3.3 V at the output. With USB connected, D1 pulls the dc-dc boost converter (U2) output up to approximately 4.7 V. When U2's output is pulled up this way, it automatically turns off and draws less than 1 μ A from the battery.

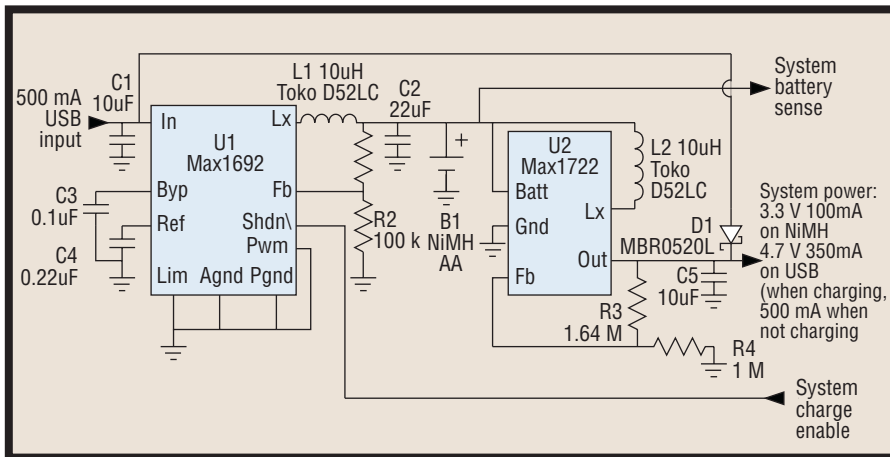

Fig. 6. Simple NiMH charge/power supply arrangement automatically hands off power to USB without a complex MOSFET switch array.

If the shift of the output from 3.3-V to 4.7-V output when USB is connected isn't acceptable, a linear regulator can be inserted in series with D1.

A limitation of this circuit is that it relies on the system to control charge termination. U1 acts only as a current source and will overcharge the cell if left on indefinitely. R1 and R2 set U1's maximum output voltage at 2 V as a safety limit. The "charge enable" input functions both as a means for the system to terminate charging and as a way to reduce USB load current prior to enumeration, if necessary, because the charger's 150-mA input current is more than one unit load.

Theory vs. Reality

With any standard, it's interesting to see how actual practice diverges

from the printed spec or how undefined parts of the spec take shape. Though USB is one of the best thought-out, reliable and useful standards efforts, it isn't immune to the real world. Some observed USB characteristics that may not be obvious, yet influence power designs, include:

- USB ports do *not* limit current. Although the USB spec provides details about how much current a USB port must supply, there are mile-wide limits on how much it might supply. Though the upper limit specifies that the current never exceed 5 A, a wise designer shouldn't rely on that. In any case, a USB port can never be counted on to limit its output current to 500 mA, or any amount near that. In fact, output current from a port often exceeds several amperes since

multiport systems (such as PCs) frequently have only one protection device for all ports in the system. The protection device is set above the total power rating of all the ports. Therefore, a 4-port system may supply more than 2 A from one port if the other ports are not loaded. Furthermore, while some PCs use 10% to 20% accurate IC-based protection, others use less accurate polyfuses (fuses that reset themselves) that will not trip until the load is 100% or more above the rating.

- USB ports rarely, if ever, turn off power. The USB spec isn't specific about this, but it's sometimes believed that USB power may be disconnected as a result of failed enumeration, or other software or firmware problems. In actual practice, no USB host shuts off USB power for anything other than an electrical fault (such as a short). Most notebook and mother-board makers are unwilling to pay for fault protection, let alone smart power switching. So no matter what dialog takes place between a USB peripheral and host, 5 V (at either 500 mA or 100 mA, or even maybe 2 A or more) will be available. This is born out by the appearance in the market of USB-powered reading lights, coffee mug warmers, and other items that have no communication capability. They may not be "compliant," but they function.

PETech

1. Maxim Integrated Products holds a U.S. patent on all forms of USB Lithium-battery charging.

**Capitalize on the Explosive Growth of the Internet
with Our Online Opportunities**



PETechTimes
FOR ENGINEERS, DESIGNERS AND INTEGRATORS

PETech Times, an electronic newsletter, addresses the interests and needs of readers concerned about engineering, design and integration of power electronics system applications.



POWER ELECTRONICS
TECHNOLOGY E-Zine

The Power Electronics Technology E-Zine is an electronic version of the monthly print publication.

Go to www.powerelectronics.com to subscribe